



Mobile Computer

RT40

User Manual



Contents

About the Guide	1
Introduction	1
Service information	1
Unpacking	2
Technical Specifications	3
Getting Started	6
Major Parts	6
Accessories	7
Installing SD/SIM Card	10
Charging The Device	11
Charging Precautions	12
Turn On/Off RT40	13
Un - Locking the Screen	14
Home Screen	16
Status Icons	17
Notification Icons	18
Quick Access Panel	19
Edit Quick Settings Panel	20
Remove The Application From The Home Screen Or Create A Folder ...	21
Add Widgets To The Home Screen	22
Home Settings+Wallpapers	23
Device Setting	24
Access Device Settings	24
Device Settings	25
Network & Internet	27
Network details	28
Hotspot & internet	29

Contents

Bluetooth Setting	30
Apps & notifications	31
Notification, Advanced-Default apps	32
Battery	33
Display	34
Night Light+Sleep	35
Sound	36
Do not disturb+Advanced	37
Storage	38
Privacy	39
Location	40
Accounts	42
Accessibility	43
Digital Wellbeing & parental controls	45
System	46
About phone	46
Language & input	47
Data & time	48
About phone	49
Scanner Settings	50
ScanWedge Profile	51
Feature Settings	52
Remap Key	53
Docking Station	54
Application	55
Application Window	55
Switching Between Recent Apps	56
Apps Icon	57
App Market	60

Contents

Clock	61
Contacts	62
Enterprise Launcher	63
Messaging	64
Maintenance and Troubleshooting	65
Maintenance Equipment	65
Cleaning Equipment	66
Troubleshooting	68
Precautions	70
Warranty Policy	71

About the Guide

Introduction

This Guide offers information on the usage of RT40 mobile computer and its accessories.

Note: The screens and windows described in this Guide are samples, which can differ from the actual ones.

Service information

You can visit the official website (<https://en.urovo.com>) of Urovo Technology Co., Ltd. (hereinafter referred to as Urovo) whenever possible to gain quick network support services:

Click the search box and enter corresponding product model to query the machine's configuration information. Click maintenance query to query information of the nearest service center or enter the serial number (SN) of your device in the search box for maintenance progress to query the maintenance state to follow up the state of the device in maintenance in time! Service hotline: 400-888-6989.

Please offer the following information while contacting the Support Center:

- Device SN (Serial Number)
- Model or product name
- Software type and version number: check the device "Settings-

About the Guide

System-About Phone"

Thanks for your cooperation!

Provision of document feedback

If you have any comment, question or advice on this Guide, please e-mail to tech@urovo.com 或 service@urovo.com

Unpacking

1. Please carefully remove all the protective materials around RT40 and keep the device case for storing and transporting the device in the future.
2. Please check the following elements:
 - RT40 intelligent terminal×1
 - Adapter×1
 - USB cable×1
 - Quick start guide×1
3. Inspect the device for damage. If any equipment is damaged or missing, please contact customer service support or the local distributor.
4. Please remove the screen shipping protective film before using.

Technical Specifications

Item	Description
OS	Android Q (10)
Processor	Octa-core 1.8GHz
Storage	3GB RAM/ 32GB ROM 4GB RAM/ 64GB ROM (optional)
Extension	microSD card, Max.128GB extension
Dimension	199 x 58(handle) x29(thinnest) mm (78.34 x 22.83 x 11.41 in)
Weight	425g
Screen	4 inch 480*800 pixel
Cover glass	Corning Gorilla
Main battery	3.85V 5200mAh Support battery swap, exchange battery without boot-up
Charging time	Less than 3 hours

Technical Specifications

Item	Description
Voice	Earpiece, speaker, microphone Support PTT (Push-to-Talk), speaker loudness over 100dB at 10cm
Buttons	38 keys isolation keyboard
Camera	Rear camera: 13M pixel with flashlight.
Sensor	Light sensor, proximity sensor, e- compass
Scanner	Standard range scanner and extended range scanner are optional Support all industry-leading 1D/2D barcode on paper or screen
Slot	Nano SIM*1, PSAM/ SIM*1 (self-adaption)
WAN	2G/3G/4G
Bluetooth	BT 5.0 + BR/EDR + BLE
WIFI	802.11 a/b/g/n/ac/d/e/h/i/k/r/v/w 2.4GHz/ 5GHz
GNSS	GPS, BeiDou, GLONASS, Galileo

Technical Specifications

Item	Description
Working temperature	-30° C ~ +50° C (Equipped with heater of screen & imager window)
Storage temperature	-40° C ~ +70° C
Humidity	5% ~ 95% RH (non-condensing)
Drop test	1.8m (5.9 ft.) flat concrete
Tumble test	1000 times 1m (3.3 ft.)
IP rate	IP68(Standard type)
ESD	±15kV air, ±8kV direct

Getting Started

Major Parts

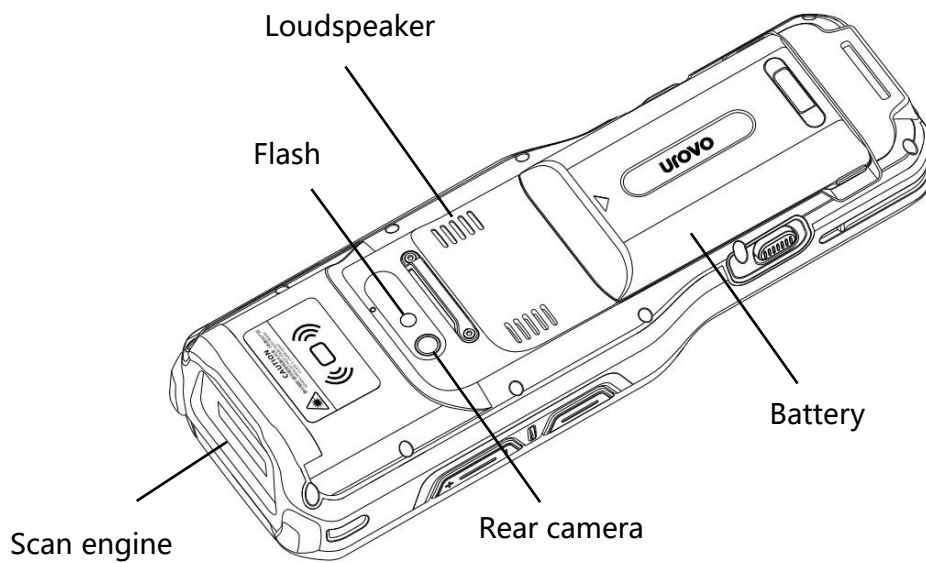
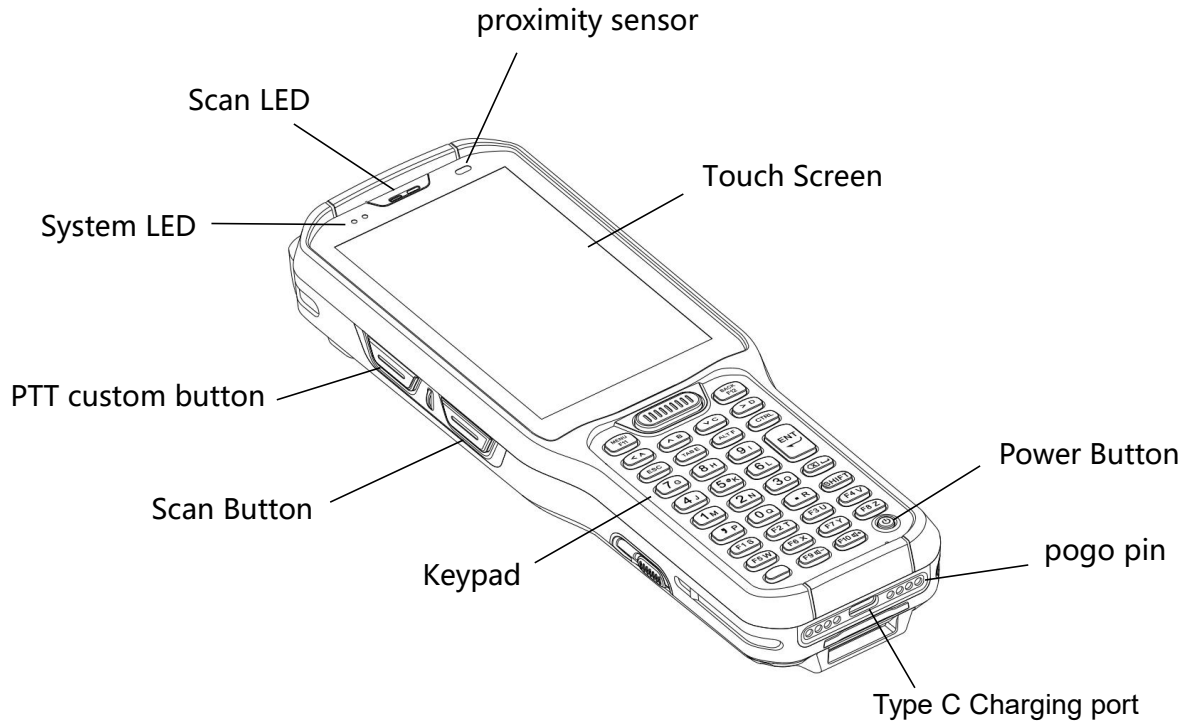

Accessories

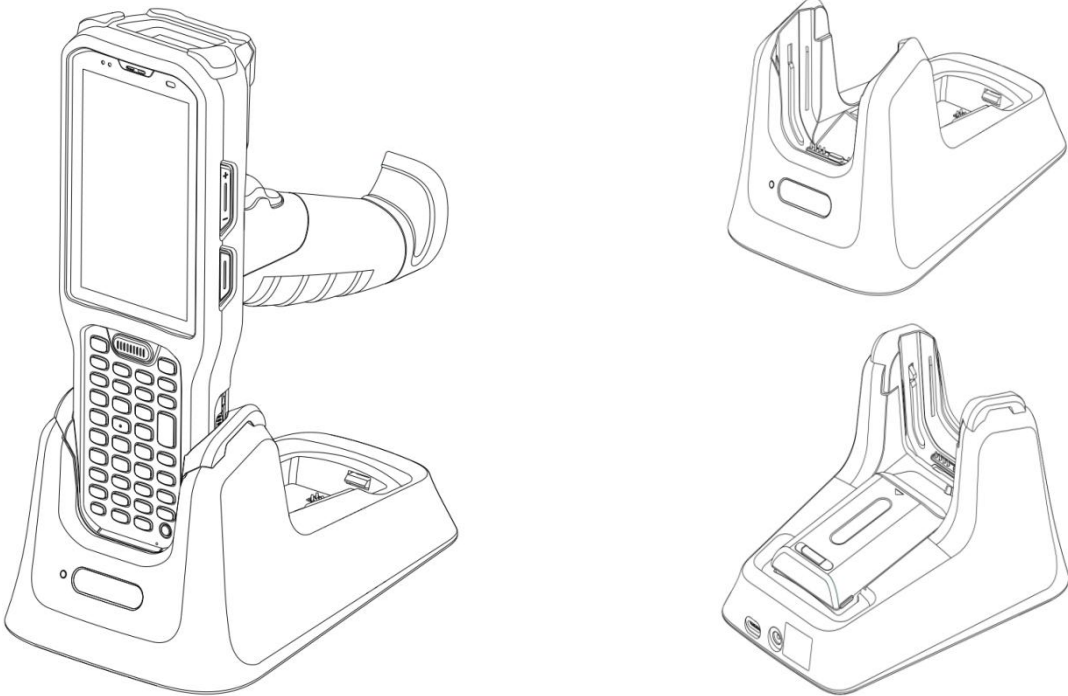

Single Charging Cradle

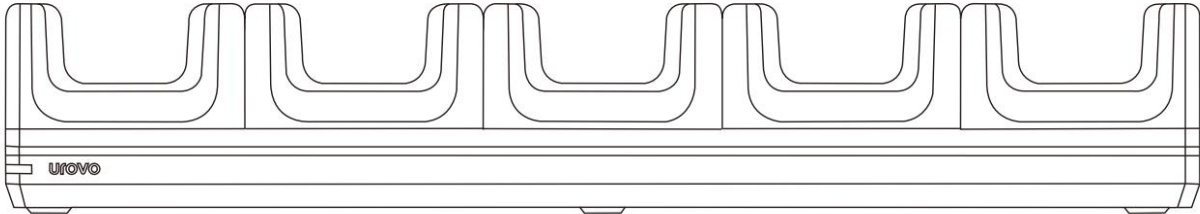

5-Slot Charging Cradle (5 device)

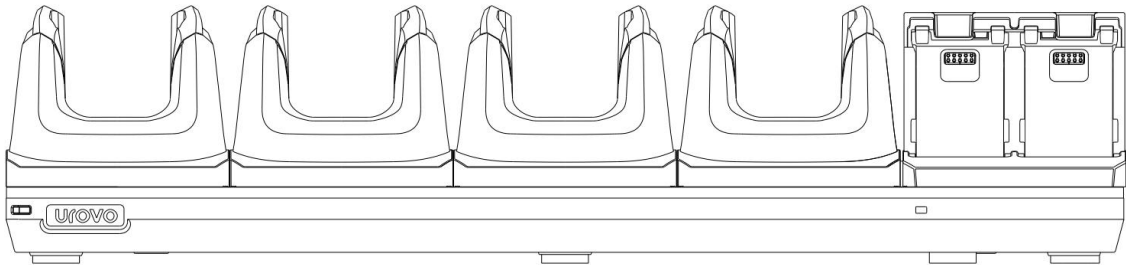

5-Slot Charging Cradle (4 devices and 4 batteries)

Getting Started

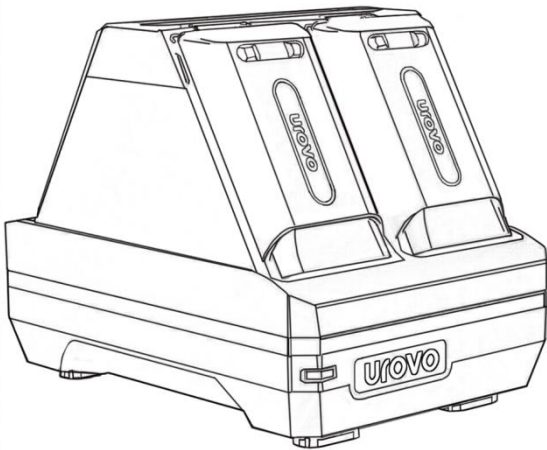

4-Slot Battery Charging Cradle

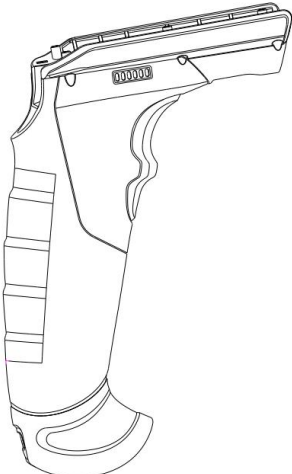

Gun Grip

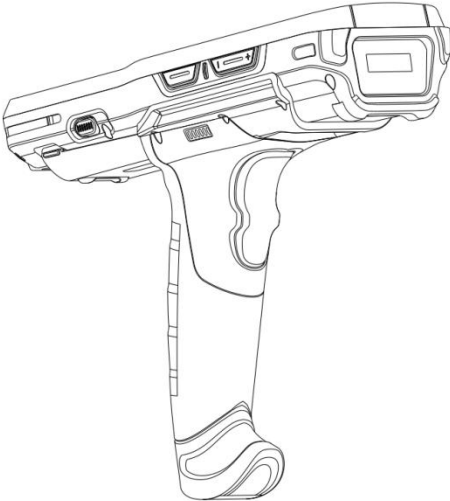

Insert The Device Into The Gun Grip

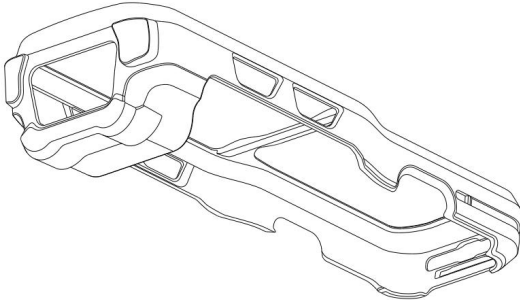
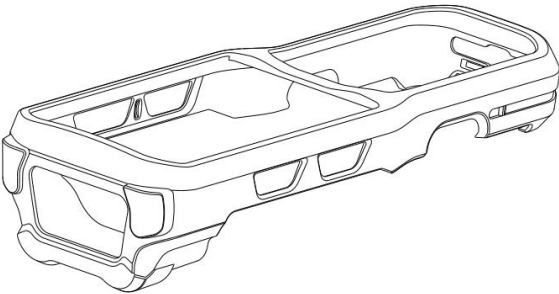

Boot Case

Getting Started

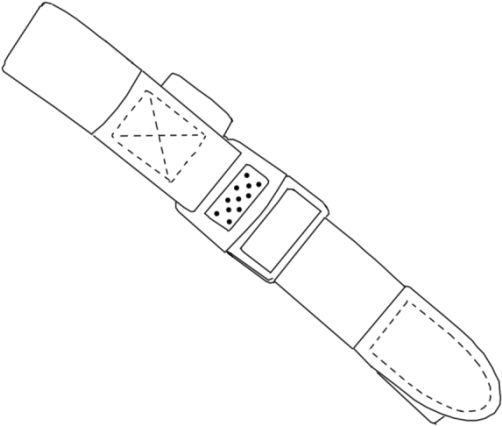

Hand Strap
Support Standard Version RT40

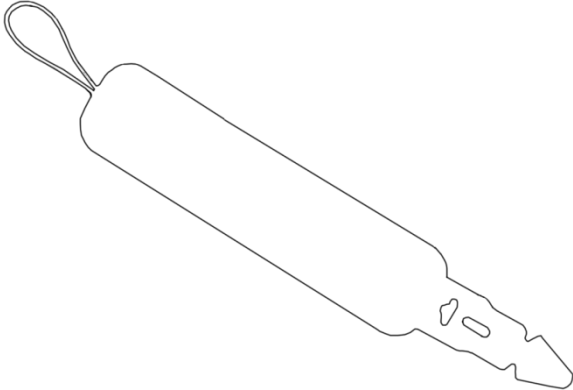

Hand Strap
Support Gun Grip

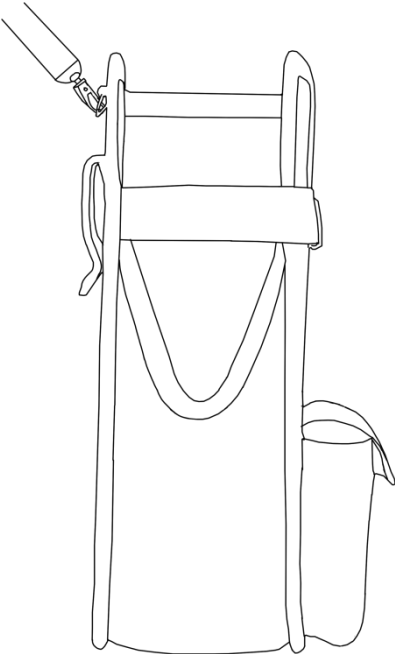

Holster

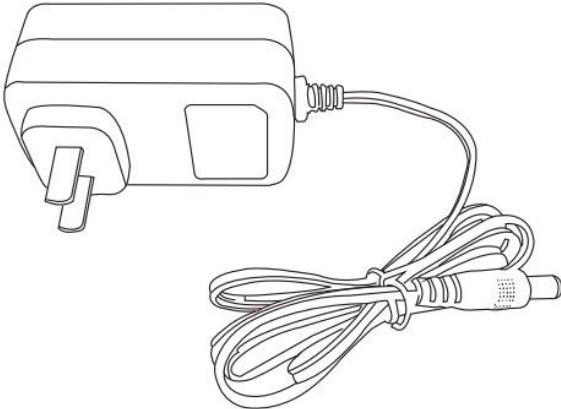

Power Adapter

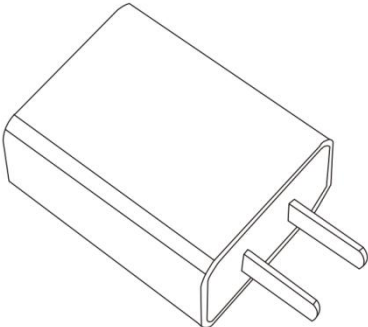

Adapter

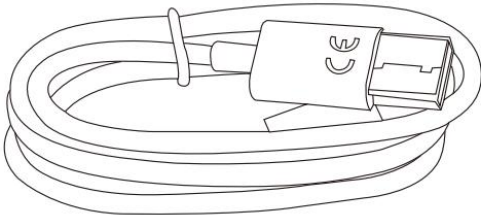

USB cable

Installing SD/SIM Card

1. Press the buttons on both sides to remove the battery.

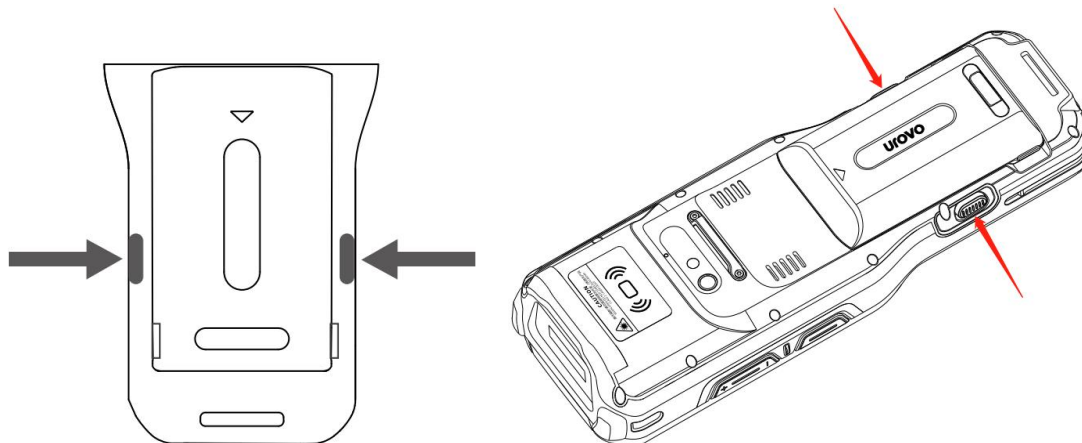

2. Take card out(as shown).

Insert the SIM card /TF card into the corresponding slot in the correct direction as shown in the figure.

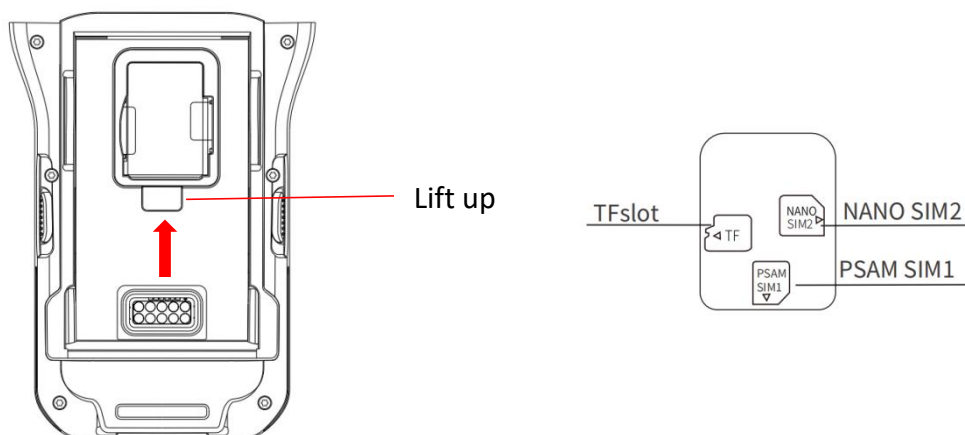

- Note:
1. SIM1 support PSAM or Mini SIM cards;
 2. SIM 2 support Nano SIM cards



Attention: Use proper electrostatic discharge (ESD) precautions to avoid damaging the SIM card. Proper ESD precautions include, but not limited to, working on an ESD mat and ensuring that the user is properly grounded.

Charging The Device

To charge the main battery:

1. Connect the charging accessory to the appropriate power source;
2. Insert the RT40 into a cradle or attach to a cable. The RT40 turns on and begins charging. The Charging/Notification LED red then turns green when fully charged.

Charging With Cradle

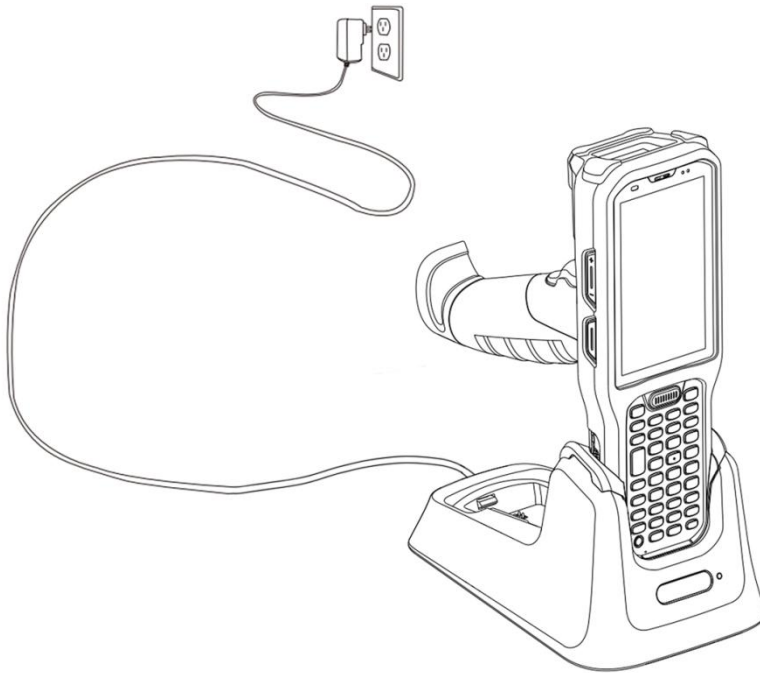

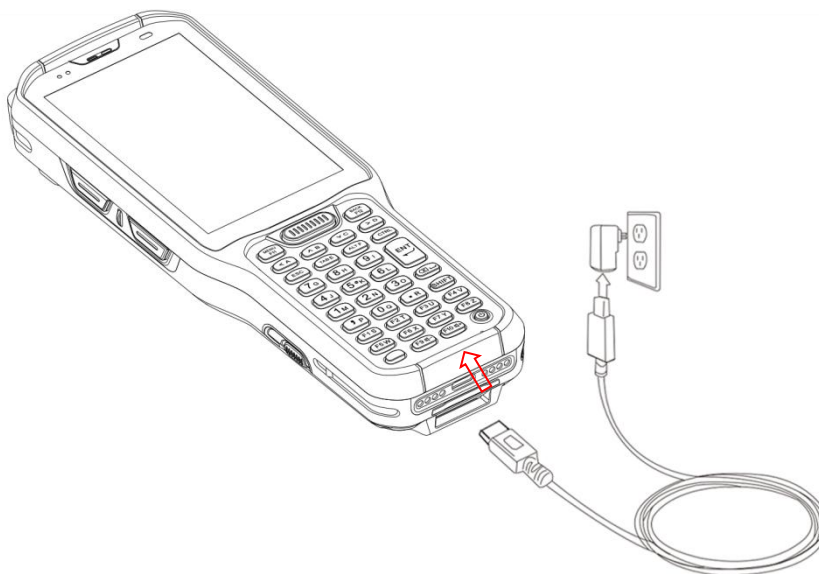

Charging with USB Cable



Charging Precautions

1. Please do not use or charge the device in any environment with too high or low temperature;
2. Please charge the battery with the product's charger in standard configuration or desktop charger only;
3. If the device (including the battery) is not used for the moment, please separately store the battery and device and pack them in PE bags or other insulated bags in the original package in case they become damp or contact with other electronic devices. Do not store the unpacked battery in a stack;
4. Please do not idle the device for over 3 months; be sure to charge and discharge the battery not used for the moment once per 3 months, where the stored battery should be 60% ~ 70% charged (i.e., 3.8V ~ 3.9V);
5. The lithium battery should be stored somewhere cool, dry and ventilated. It is advised to be stored in a 0 ~ 28°C environment.

Charging Indicators:

State	LED	Indication
Off		RT40 is not charging. RT40 is not inserted correctly in the cradle or connected to a power source. The charger/cradle is not powered
Long red light		RT40 is charging
Long green light		Charging complete

Turn On/Off RT40

Turn On

1. In the shutdown of long press the "power key";
2. When RT40 goes into startup mode, it vibrates;
3. Release the "Power Key" and wait until RT40 finish booting.



If you cannot turn on your RT40, try the below steps:

1. To turn on RT40, the battery needs to be charged certain level, Please charge first;
2. Press and hold the "power key" for over 10 seconds to force reboot.

Turn Off

Press the power button for a long time in the power-on state until the shutdown prompt appears. Click "Power off".

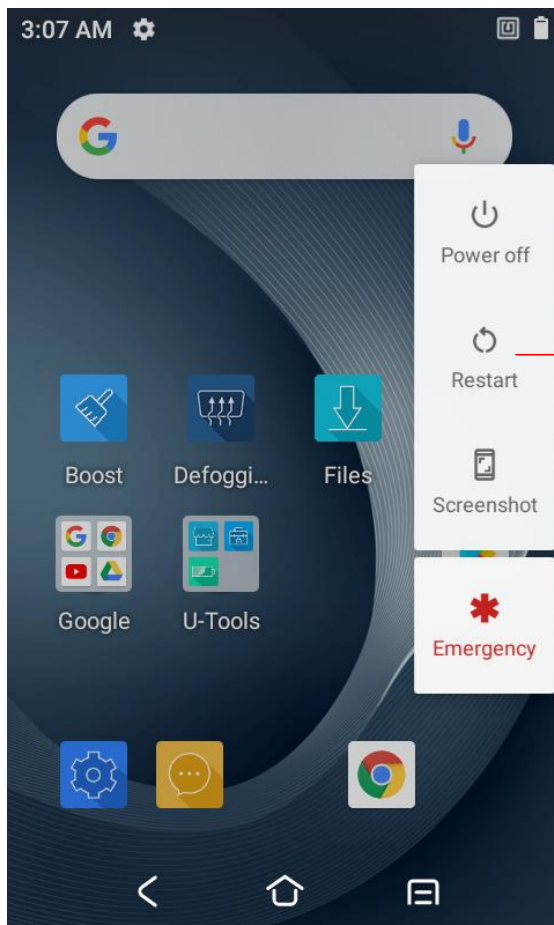

Restart the device.

Un - Locking the Screen



Lock Screen

Use the Lock screen to protect access to data on the device. Some email accounts require locking the screen.

When locked, a pattern, PIN, or password is required to unlock the device. Press the Power button to lock the screen. The device also locks after a pre-defined time-out. Press and release the Power button to wake the device. The Lock screen displays.

Swipe the screen up to unlock. If the Pattern screen unlock feature is enabled, the Pattern screen appears instead of the Lock screen. If the PIN or Password screen unlock feature is enabled, enter the PIN or password after unlocking the screen.

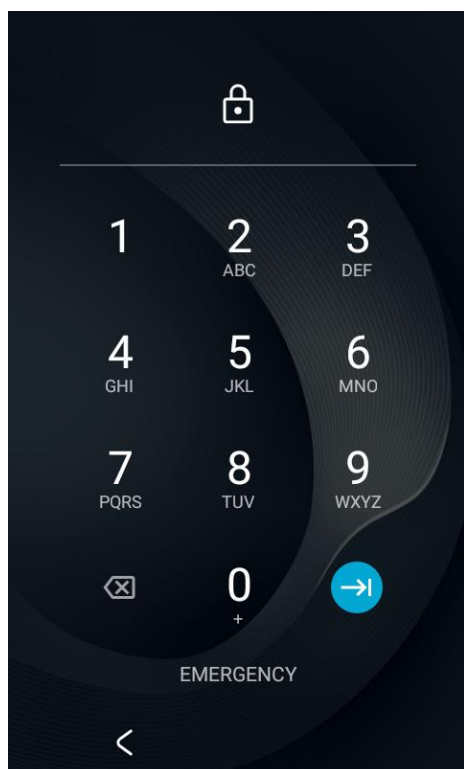

PIN Screen

If the user enters the PIN, password or pattern incorrectly five times, they must wait 30 seconds before trying again.

If the user forgets the PIN, password or pattern contact the system administrator.

Un - Locking the Screen

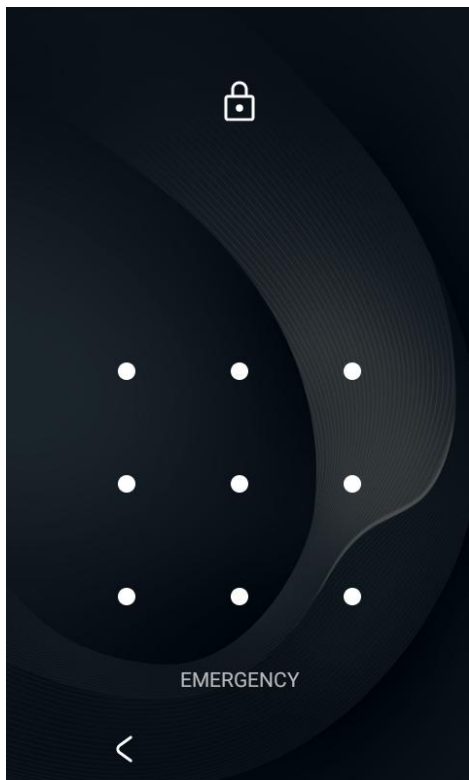

Pattern Screen
Unlock with pattern.

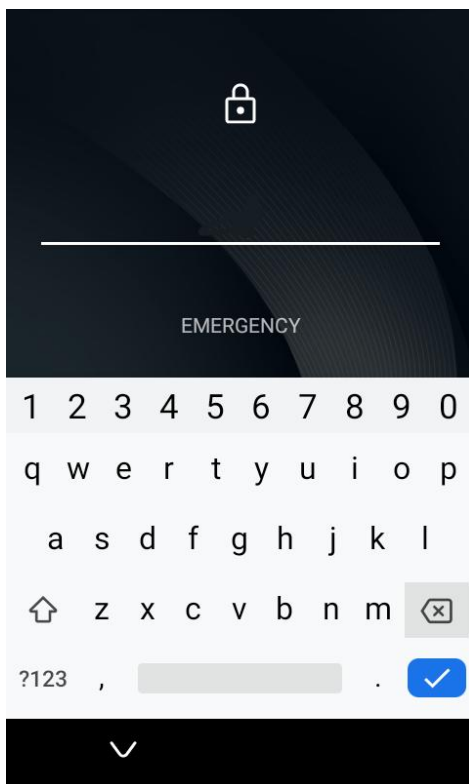

Password Screen
Unlock with a password.

Home Screen

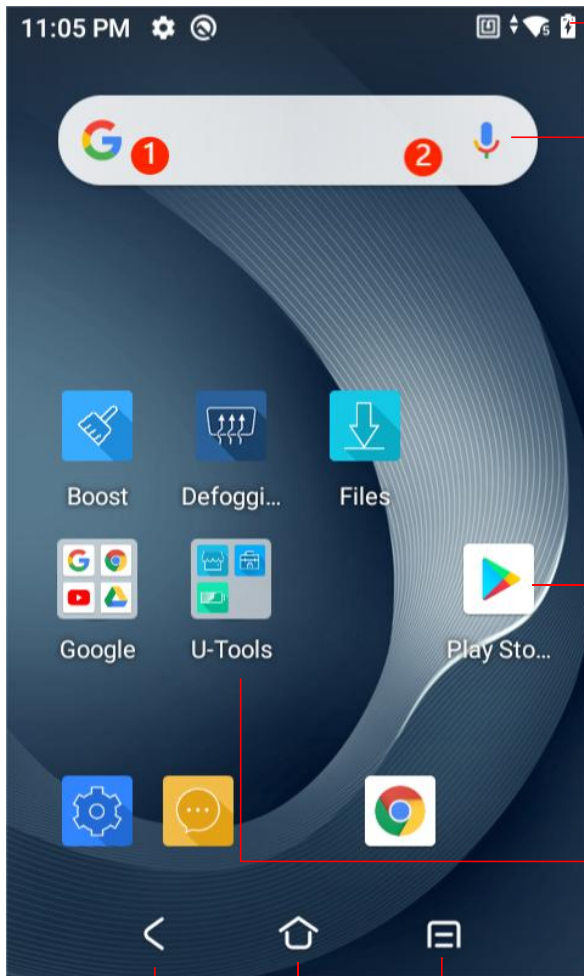

Status Bar

Displays the time, status icons , and notification icons.

Search Bar

Touch 1 to search by text.
Touch 2 to search by voice.

Application

Click on an icon to run an application.

Folder

Contains apps.

Recent Button

Displays recently used applications.

Back

Displays the previous screen.

Home

















Displays the Home screen.



















Note: Some Status icons may not appear in the Status bar if there are too many icons to display.

Some of the status icons are listed on the next page.

Status Icons

Icon	Description
	Alarm is active.
	Main battery is fully charged.
	Main battery charge is low.
	Main battery charge is very low.
	Main battery is charging.
	All sounds, except media and alarms, are silenced and vibrate mode is active.
	Do Not Disturb mode active.
	Airplane Mode is active. All radios are turned off.
	Bluetooth is on.
	The device is connected to a Bluetooth device.
	Connected to a Wi-Fi network.
	Not connected to a Wi-Fi network or no Wi-Fi signal.
	Connected to an Ethernet network.
	Speakerphone enabled.
	Portable Wi-Fi hotspot is active.
4G LTE	Connected to a 4G LTE/LTE-CA network ¹ .
	Roaming from a network.
	No SIM card installed.

Notification Icons

Icon	Description
	More notifications are available for viewing.
	Data is syncing.
	Indicates an upcoming event. Non-GMS devices only.
	Indicates an upcoming event. GMS devices only.
	Open Wi-Fi network is available.
	Song is playing.
	Problem with sign-in or sync has occurred.
	Device is uploading data.
	Device is downloading data when animated and download is complete when static.
	Device is connected to or disconnected from virtual private network (VPN).
	Preparing internal storage by checking it for errors.
	Call is in progress.
	One or more voice message is in mailbox.
	Call is on hold.
	Call was missed.
	Headset is connected to the device.
	PTT Express Voice client status. See the PTT Express PTT Notification Icons for a complete list.

Quick Access Panel

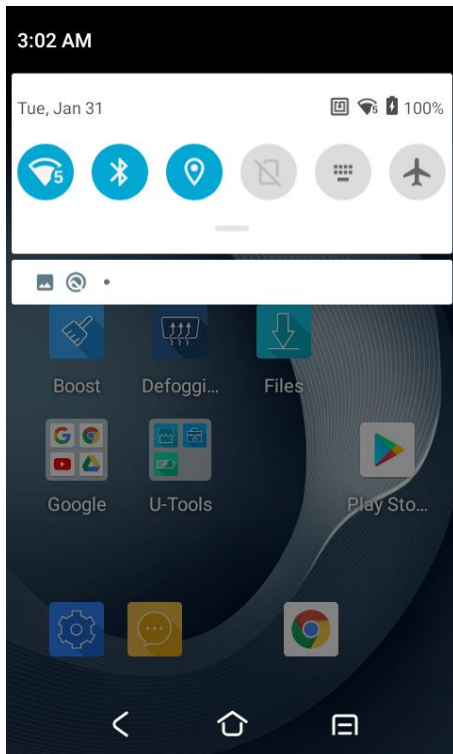

Notification panel

When there is a notification from the Android (system) or the App, you can check details by dragging down the "Status Bar".

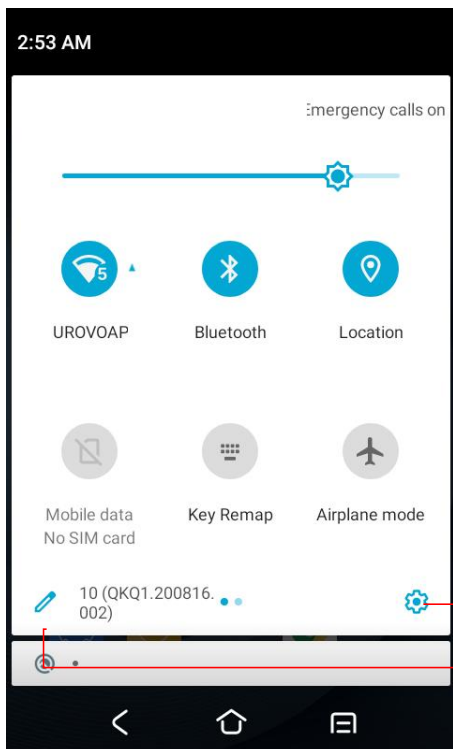

Quick setting panel

You can access the "Quick setting panel" by dragging down the "Notification panel".

Device Settings

Touch to access device Settings.

Edit Quick settings panel

Touch the Edit icon to change the order of icon in the Quick settings panel.

Edit Quick Settings Panel

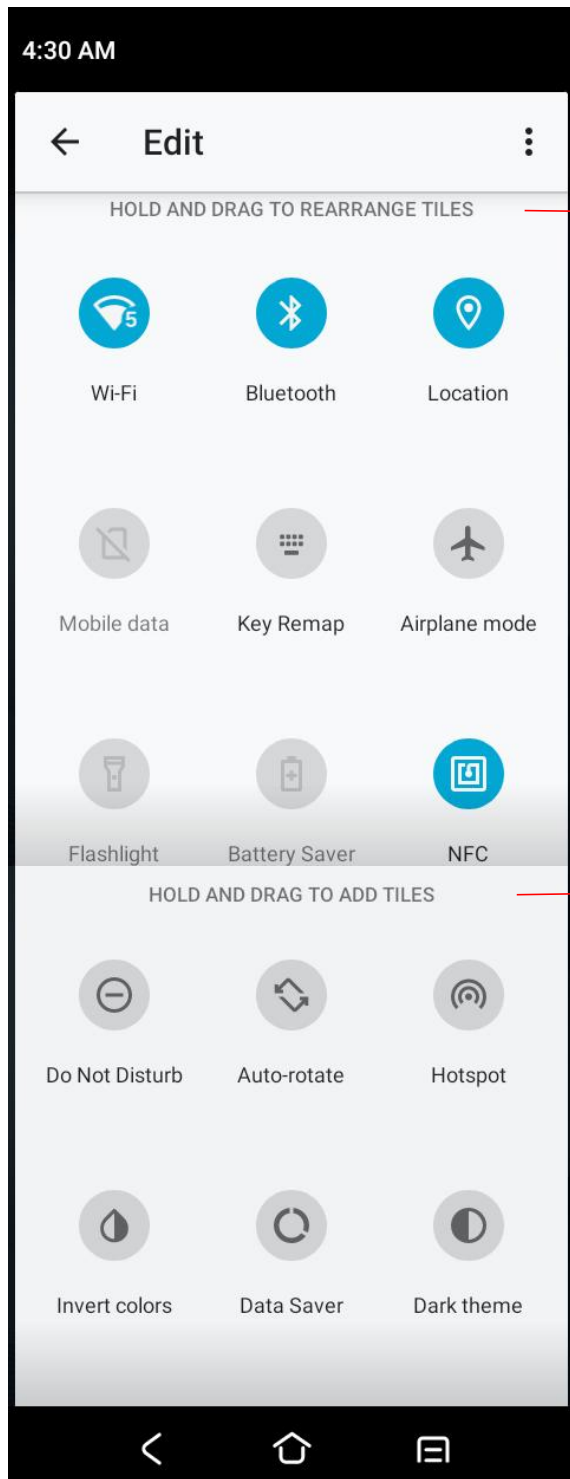

Edit Quick settings panel

Hold and drag to rearrange tiles, and change the order of icons in the Quick settings pane.

By dragging the icon, you can customize the Quick settings panel.

Remove The Application From The Home Screen Or Create A Folder

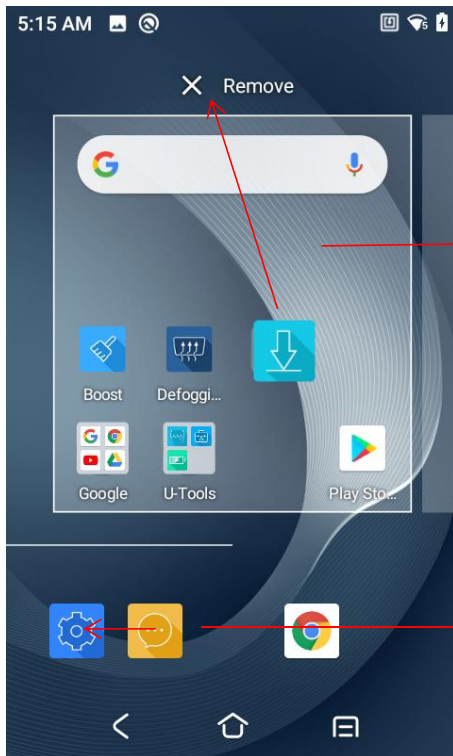

Remove the application from the home screen

Delete the application, drag its icon into the "remove" area, and release.

Create A Folder

1. Touch and hold one app icon;
2. Drag the icon and stack it on top of another icon;
3. Lift and release.

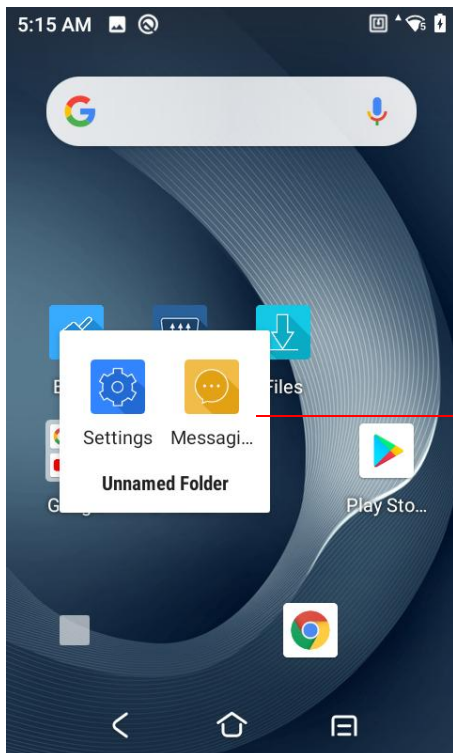

Unnamed Folder

1. Touch the folder;
2. Touch the title area and enter a folder name using the keyboard;
3. Touch anywhere on the Home screen to close the folder. The folder name appears under the folder.

Add Widgets To The Home Screen

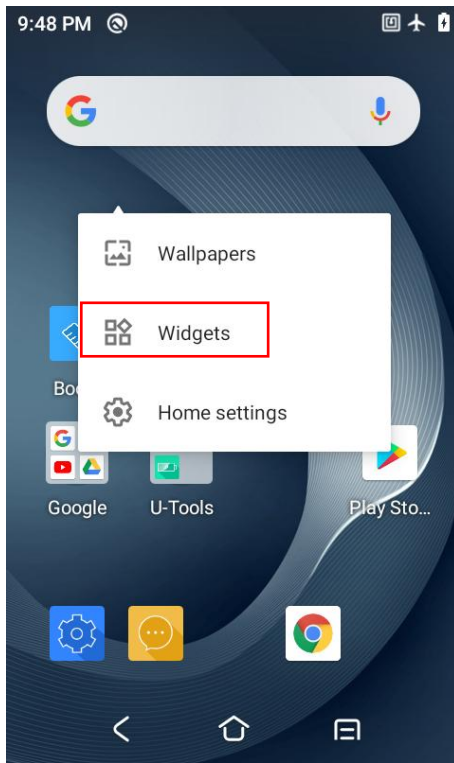

Add Widgets

Hold down on the home screen until the menu appears, and then touch the "Widgets".

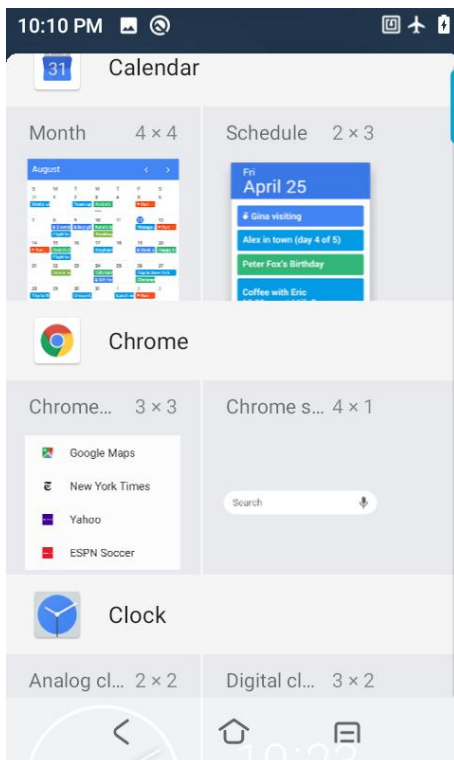

To add a widget to the Home screen

1. Scroll through the list to find widgets;
2. Touch and hold the widget until the home screen appears;
3. Position the widget on the home screen and release it.

Home Settings+Wallpapers

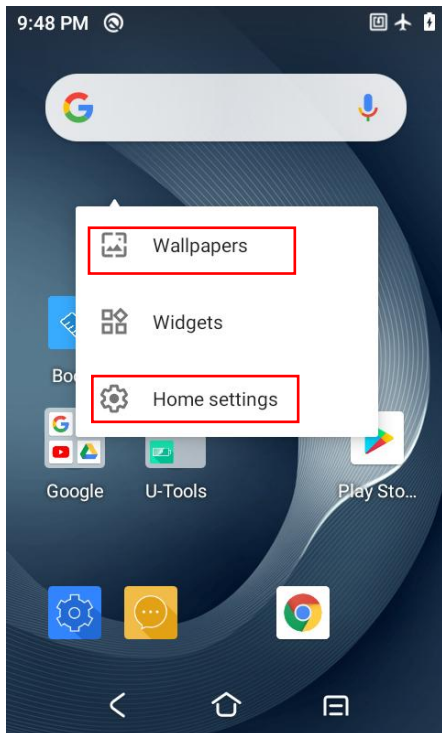

Wallpapers/Home Settings

Hold down on the home screen until the menu appears, and then touch the "Wallpapers" or "Home settings".

Wallpapers

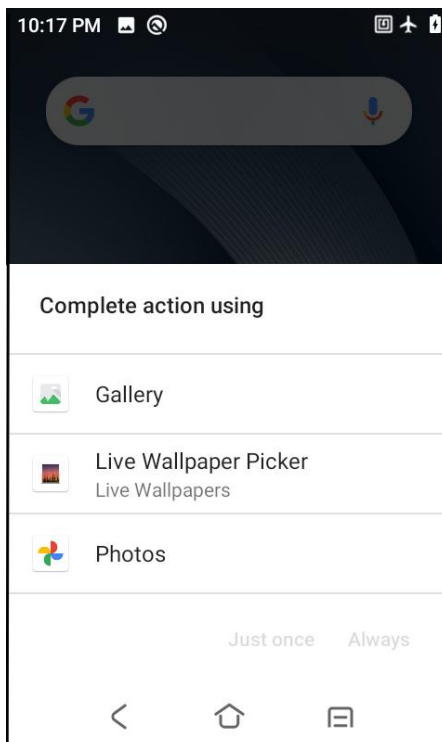

Home Settings

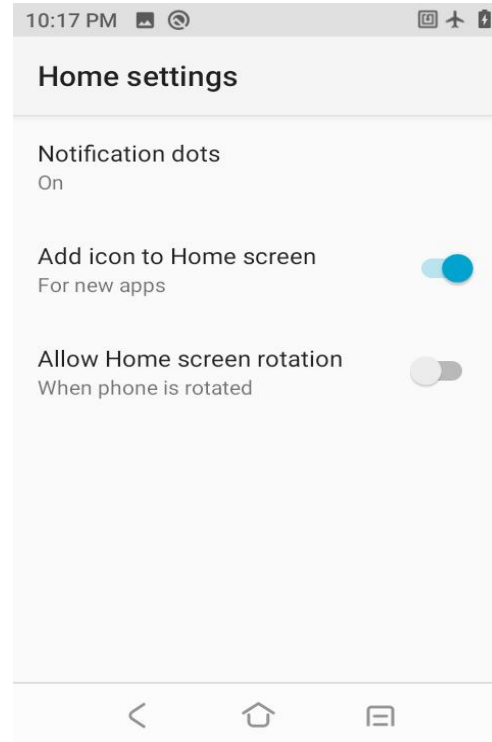

Device Setting

Access Device Settings

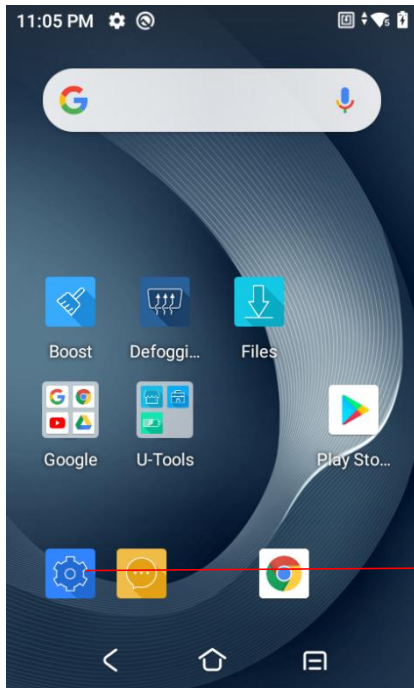

Method 1

In the home screen, tap the settings icon.

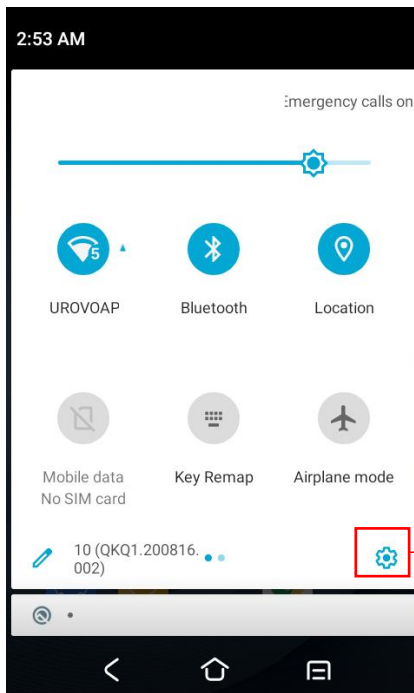

Method 2

Pull down the status bar to open the quick access panel, then tap the settings icon.

Device Settings

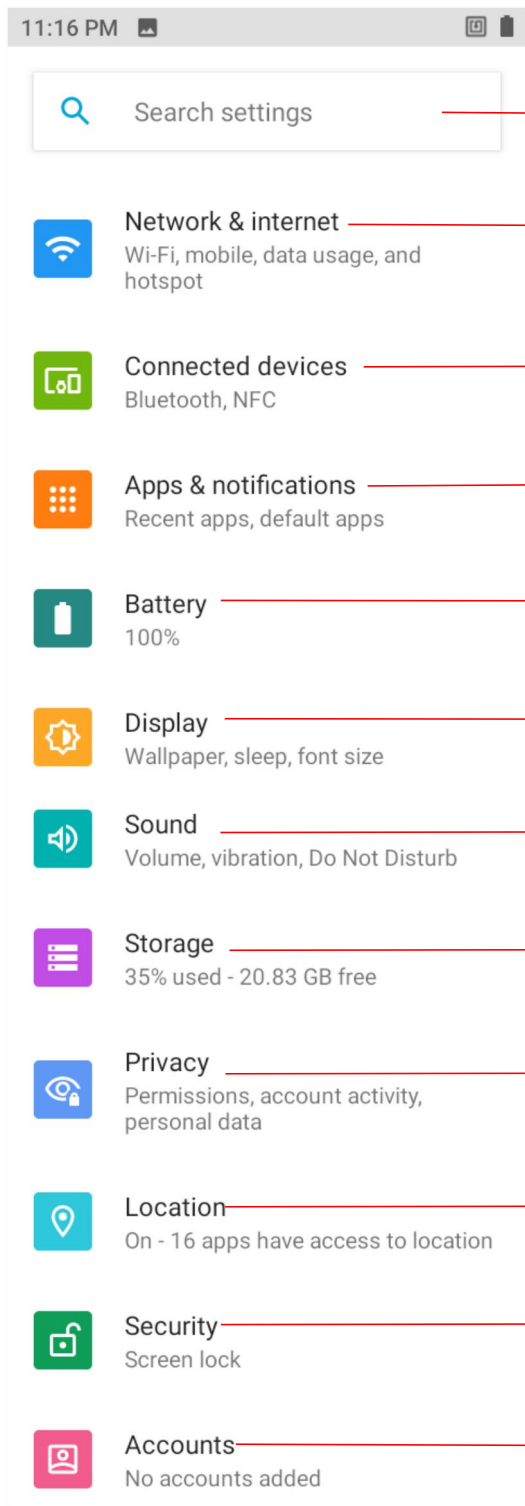

Enter keywords to find Settings.

Wireless network setup (Wi-Fi, Mobile network, Data usage, hotspot).

Bluetooth, NFC.

App Settings (Permissions, default apps).

Battery Settings (Battery percentage, Battery Saver).

Display Settings (Wallpaper, sleep, font, Size).

Sound (Volume, vibration, Do not disturb).

Storage (Storage manager).











Privacy permission, account activity, personal data.

Recent location request, Location permissions for Apps.

Security (Screen lock).

Accounts (Accounts for owner).

Device Settings

 Accessibility Screen readers, display, interaction controls	Accessibility (Screen readers, display, interaction controls).
 Digital Wellbeing & parental controls Screen time, app timers, bedtime schedules	Digital Wellbeing & Parental controls (Screen time, App times, and Bedtime schedule).
 Google Services & preferences	Google settings (Equipment service, preference)
 System Languages, gestures, time, backup	System Settings (Remap Key, About phone, Languages, Date & time, Backup, Reset options, and System update).
 About phone RT40	View device information.
Enterprise featured setting	Enterprise featured setting (Scanner settings, Remap Key and so on).
 Scanner Settings	
 ScanWedge Profiles	
 Feature Settings	
 Remap Key	
 Docking Station	

Network & Internet

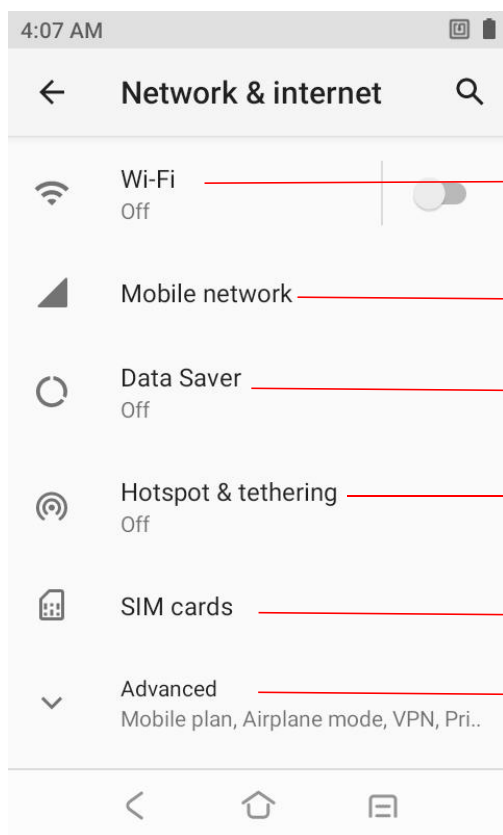

Connecting to a Wi-Fi Network.

Turn on/off Mobile data, Roaming.

Data usage (Data Usage warning, Data Limit).

Sharing the Mobile Data Connection.

Related to SIM card Settings.

Mobile plan, Airplane mode, VPN, Private DNS.

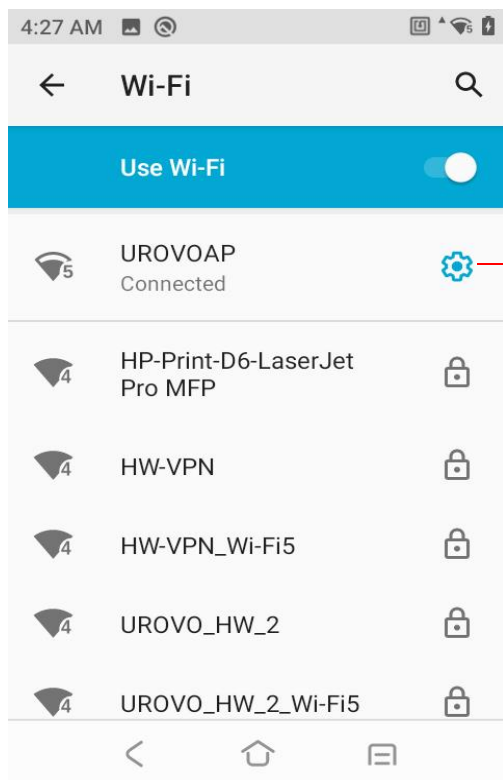

Touch the Wi-Fi item and enable the "Use of Wi-Fi". The device searches for WLANs in the area and lists them.

Click on the icon to view the network details.

Scroll through the list and select the desired WLAN network. For open networks, touch profile once or press and hold and then select Connect to network or for secure networks enter the required password or other credentials then touch Connect. The device obtains a network address and other required information from the network using the dynamic host configuration protocol (DHCP) protocol. In the Wi-Fi setting field, Connected appears indicating that the device is connected to the WLAN.

Network details

The screenshot shows the 'Network details' screen for a Wi-Fi network named 'UROVOAP'. The network is connected, and the signal strength is 'Excellent'. The screen is annotated with several red lines and text boxes:

- Search icon:** Annotates 'Searching the web.'
- Edit icon:** Annotates 'Modify network options.'
- FORGET button:** Annotates 'Remove Wi-Fi Network.'
- SHARE button:** Annotates 'Share Wi-Fi Network.'
- Advanced section:** Annotates 'Touch "Advanced".'
- Network usage section:** Annotates 'Detect automatically', 'Treat as metered', and 'Treat as unmetered.'

The 'Advanced' section is expanded, showing the following network details:

- MAC address: b4:29:3d:59:e1:8f
- IP address: 10.10.11.192
- Gateway: 10.10.10.1
- Subnet mask: 255.255.254.0
- DNS: 202.96.134.133, 114.114.114.114
- Transmit link speed: 52 Mbps
- Receive link speed: 1 Mbps

The 'IPV6 ADDRESSES' section shows the address: fe80::4d6a:c5eb:b1e7:b95

Hotspot & internet

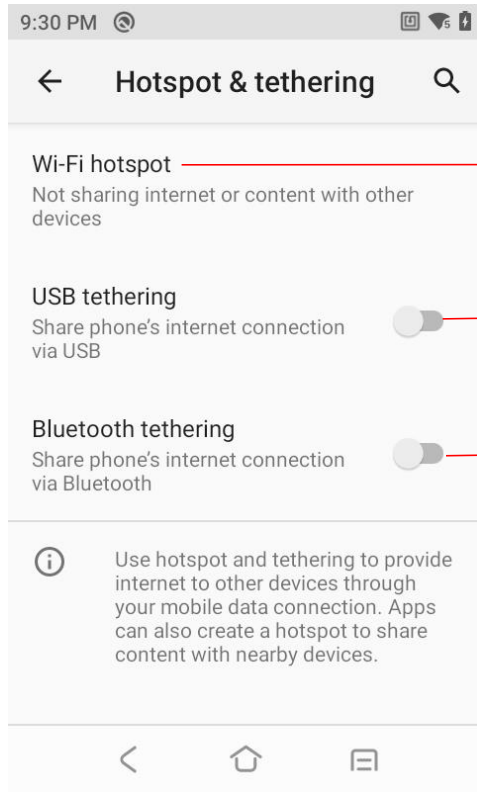

Touch to turn on/off Wi-Fi hotspot and manage hotspot Settings.

Share the device's internet connection via USB.

Share the device's internet connection via Bluetooth.

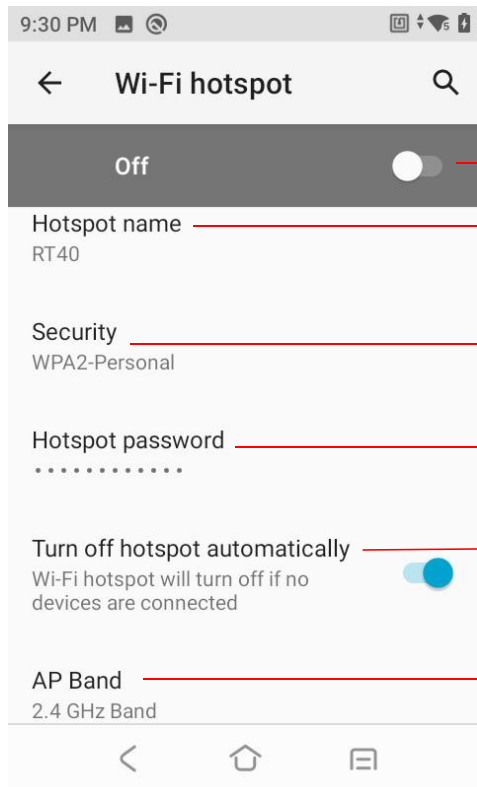

Turn on/off the Wi-Fi hotspot.

Change hotspot name.

Security (WAP2 PSK, None).

Change the hotspot password.

Turn on/off the hotspot automatically.

Touch to change AP band (2.4GHz band, 5.0GHz band).

Bluetooth Setting

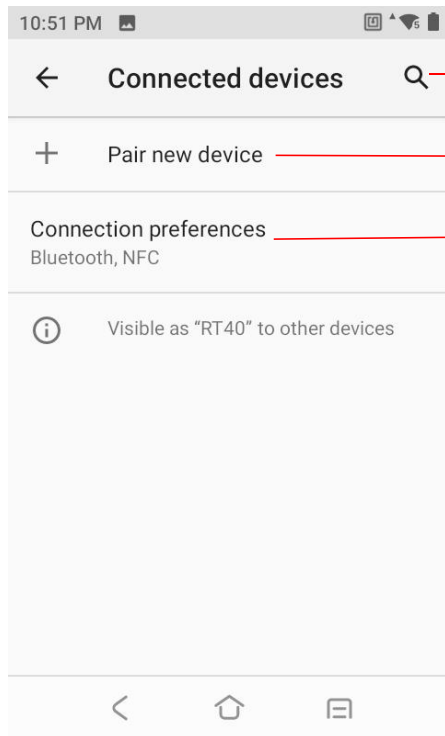

Search equipment.

Touch to rename Bluetooth name and connects new devices.

Bluetooth, NFC, Cast, Printing, Chromebook.

Enabling /Disabling Bluetooth :

1. Swipe down from the Status bar to open the Quick Access panel.
2. Touch to turn Bluetooth on/off.

The device supports Bluetooth Low Energy. Bluetooth Low Energy is targeted at applications in the healthcare, fitness, security, and home entertainment industries. It provides reduced power consumption and cost while maintaining a standard Bluetooth range.

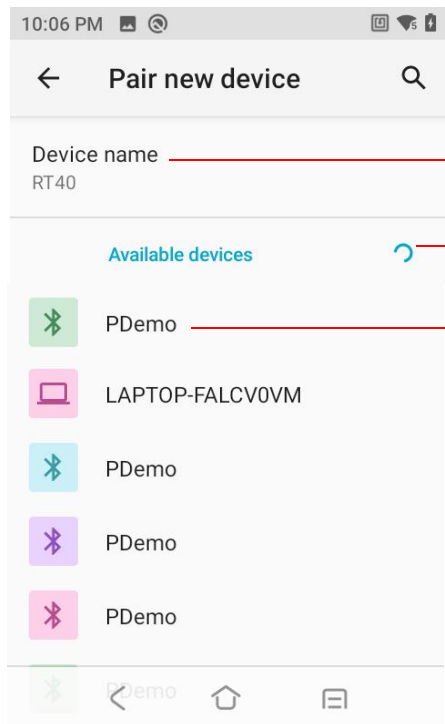

Touch to change the Device name.

Discovering Bluetooth Device.

Touch to connect Bluetooth device.

Apps & notifications

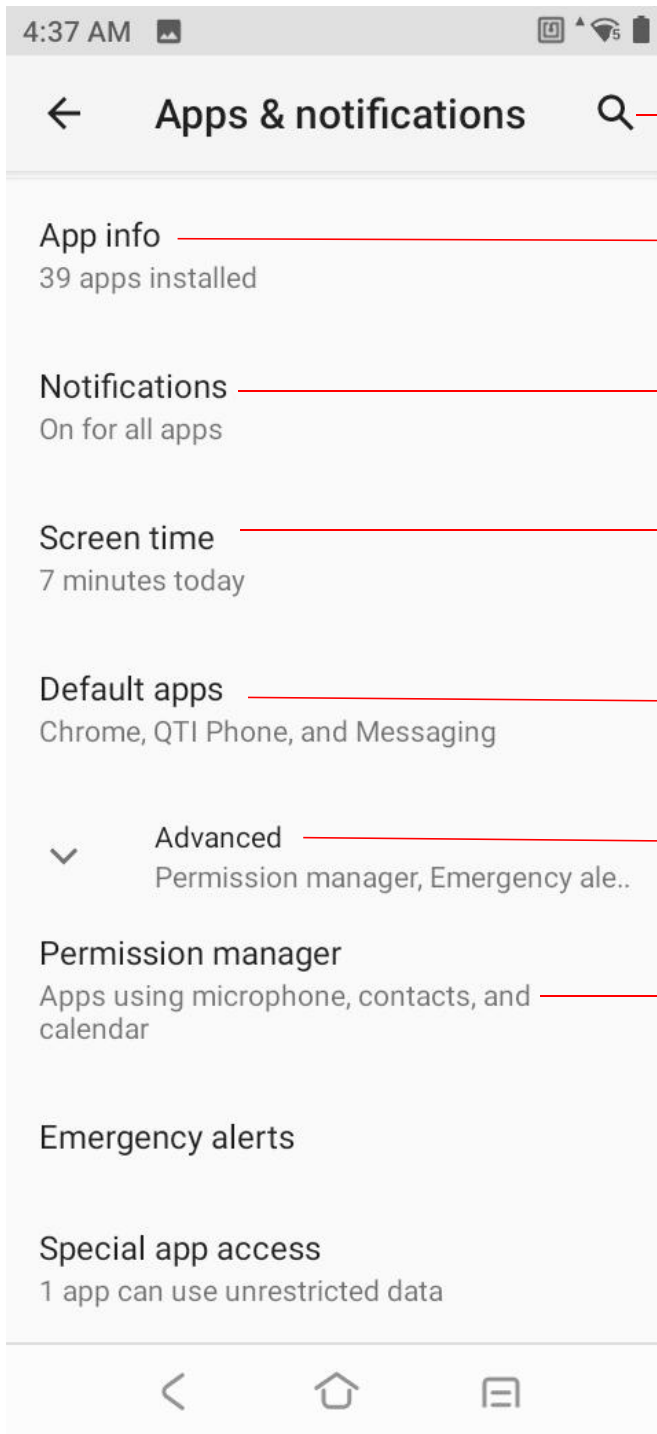

Search for Settings.

View specific information about Apps.

Notifications Settings (Default notification sound, Do not disturb).

View screen usage time, set times for apps.

Advanced Settings (Default apps, App permissions, Emergency alerts, Special app access).

Advanced Settings (Default apps, App permissions, Emergency alerts, Special app access).

View and manage App privacy permissions.

Notification, Advanced-Default apps

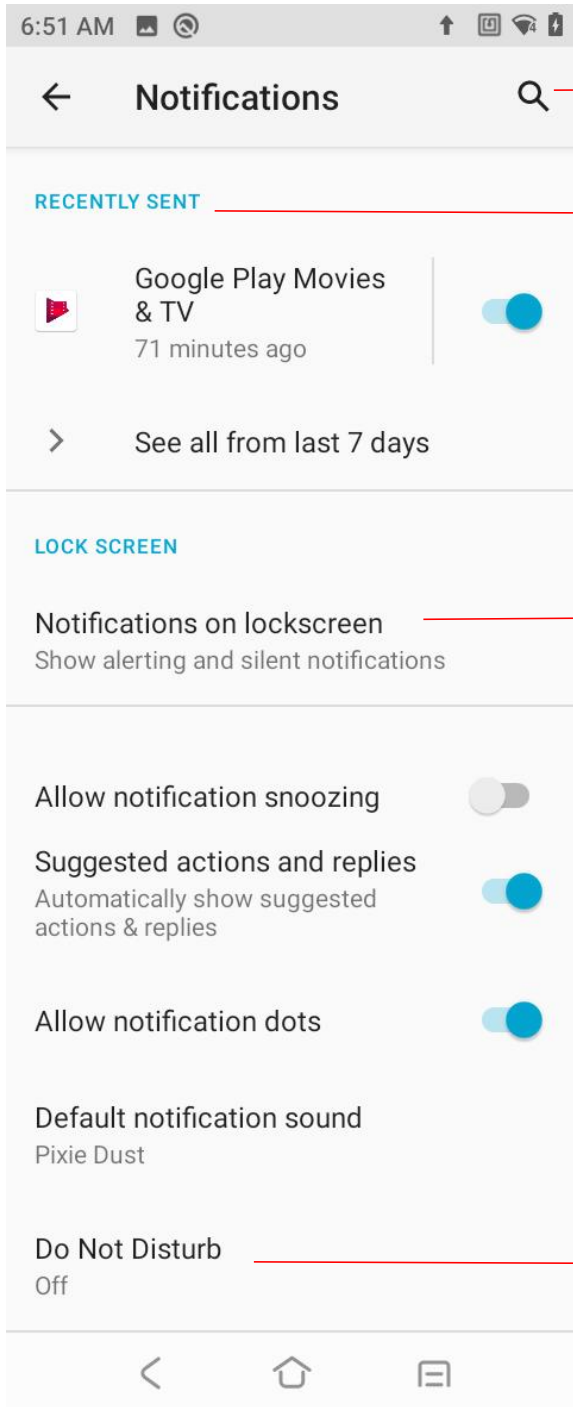

Search for Settings.

The app that sent the latest message.

Show alerting and silent notifications;
Show alerting notifications only;
Don't show notifications.

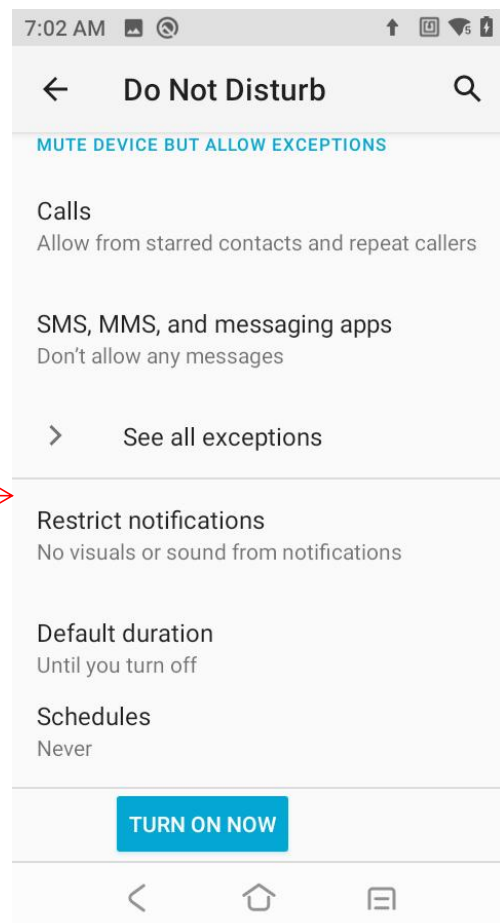

Battery

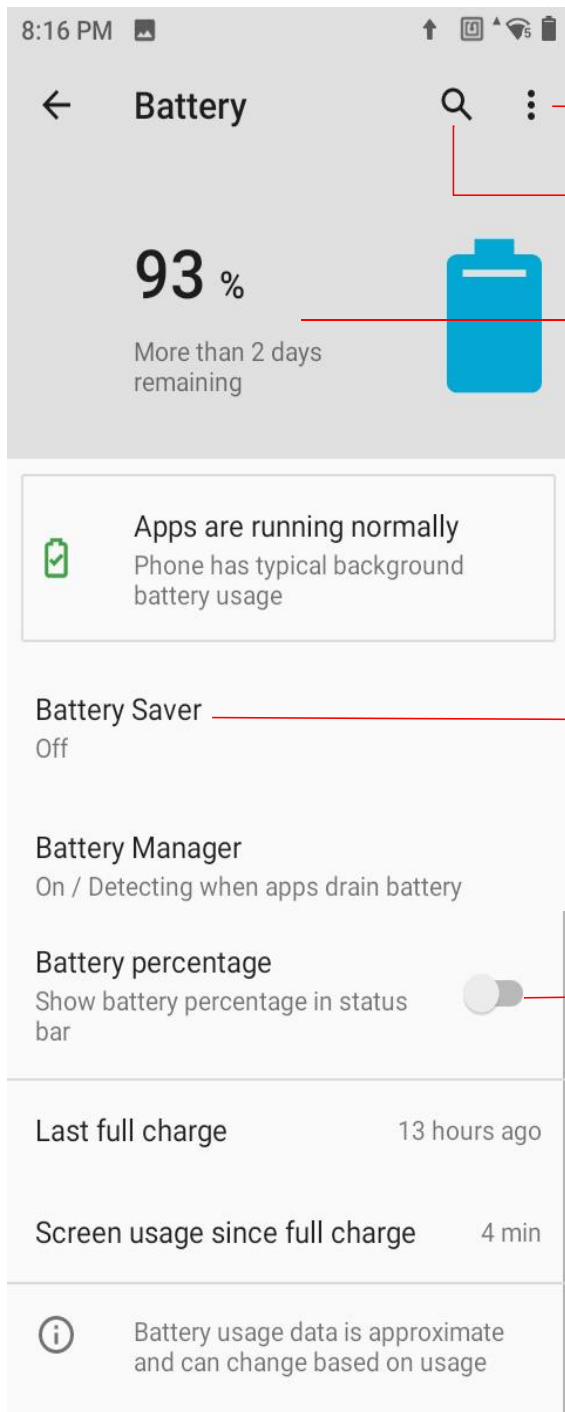

Battery usage (Monitoring Battery Usage) .

Search settings.

Remaining battery capacity and estimated working time.

Touch turn on Battery Saver (Turn on Automatically).

Touch turn on Battery percentage, and show the battery percentage in the status bar.

Display

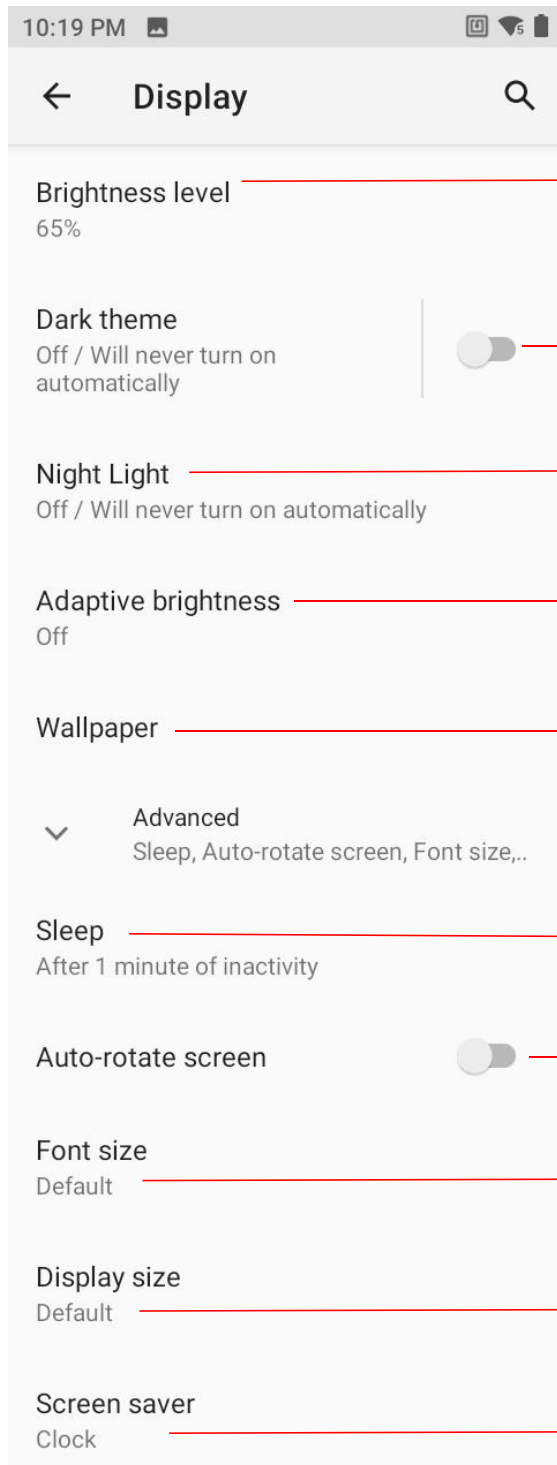

Adjust the slider to change the screen brightness.

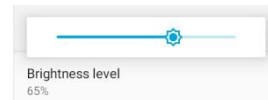

Turn on the Dark theme.

Night light tints your screen amber.

Screen brightness adjusts to the environment.

Change the screen background and decorate the phone screen.

When you don't use your phone for a long time, it will automatically go into sleep mode.

Click to turn on the automatic rotation screen.

Adjust the text font size on the screen
Screen saver Settings.

Make the items on your screen smaller or larger.

Screen saver settings.

Night Light+Sleep

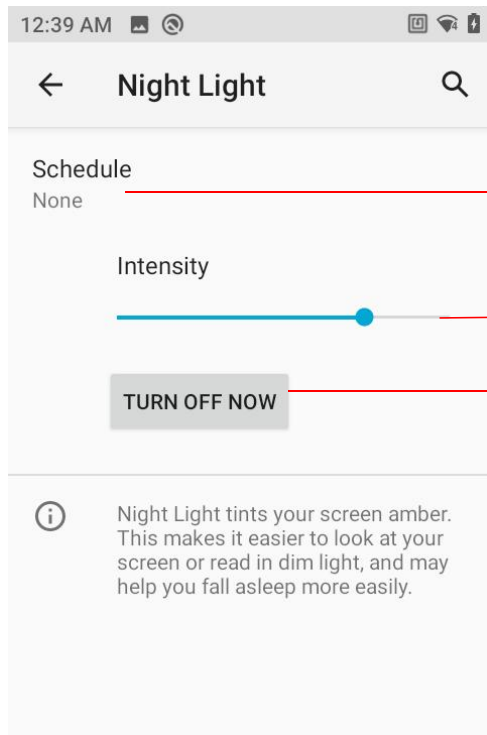

Night Light

Adjust the screen color that makes it easier to look at your screen or read in dim light.

Turn on night mode regularly (None, Turns on at the custom time, Turns on from sunset to sunrise).

Sliding dots, set the screen color concentration.

Touch turn on/off Night Light.

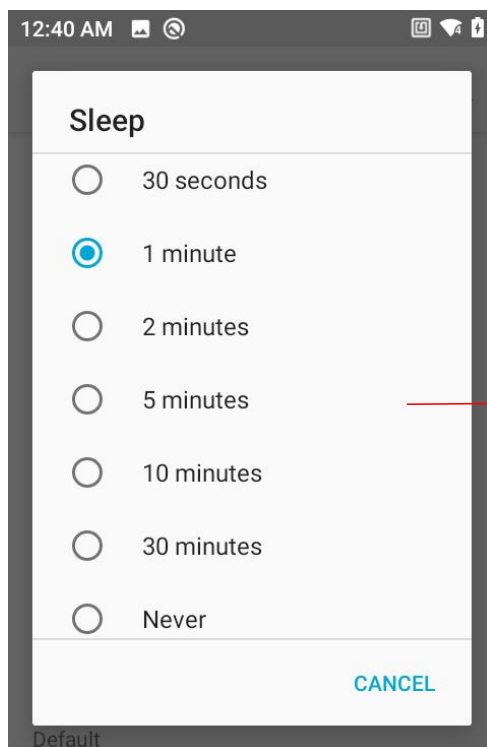

User may make RT40 sleep if not using it for a moment. As RT40 is in the sleep status, the user may directly press the power key to wake up the screen and unlock to back to the program interface. To make RT40 sleep, press the power key to turn off the screen or set sleep time. please follow below:

Select a sleep time.

Sound

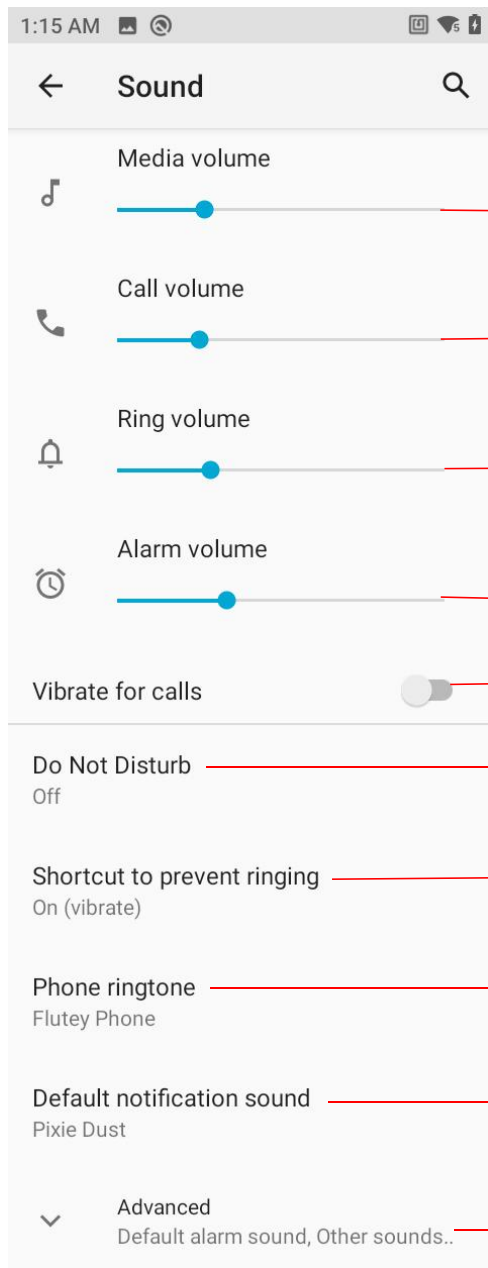

On the Home screen, swipe up from the bottom of the screen and touch  and choose Sound.

Slide the dots and set the music, games, and media volume.

Slide the dot , set the call volume.

Slide the dot , set the ring volume.

Slide the dot , set the Alarm volume.

Slide the dot , Turn On/Off also vibrate for calls.

Touch set does not disturb.

Shortcut to prevent ringing - Vibrate, Mute, Do nothing.

Touch to select the sound you want to play when the phone rings.

Touch to select the sound of the notification prompt.

Advanced-Default alarm sound, Dial pad tones, Screen-locking sounds, Charging sounds, Touch sounds, Touch vibration.

Do not disturb+Advanced

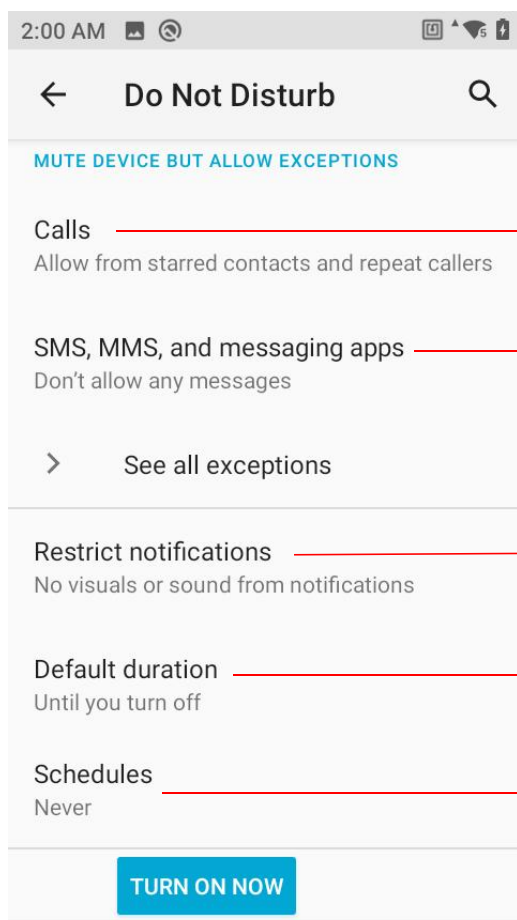

Allow calls, Starred contacts, Allow repeat callers.

Allow messages /from anyone/from contacts only/from starred contacts only/ make sound, or Don't allow any message make sound.

No sound from notifications, No visuals or sound from notifications, Custom.

Do not disturb until you turn off, Custom time, Ask every time .

Custom schedule.

Advanced Settings

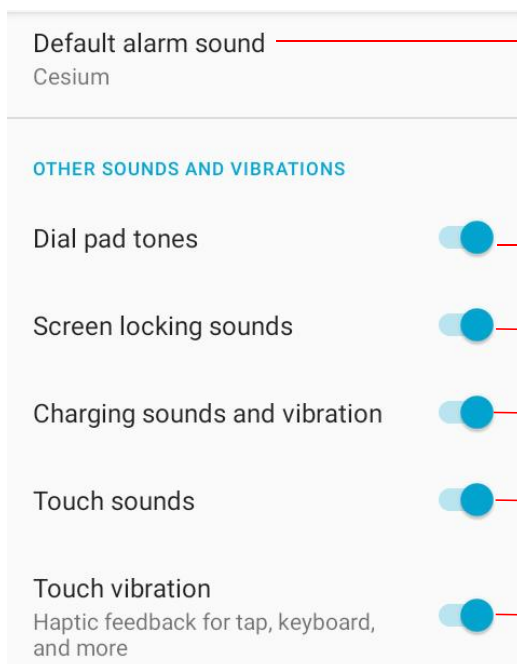

Touch change alarm sound.

Sliding dot, turn on/off dial pad tones.

Sliding dot, turn on/off screen-locking sounds.

Sliding dot, turn on/off charging sounds and vibration.

Sliding dot, turn on/off touch sounds.

Sliding dot, turn on/off touch vibration, haptic feedback for tap, keyboard, and more.

Storage

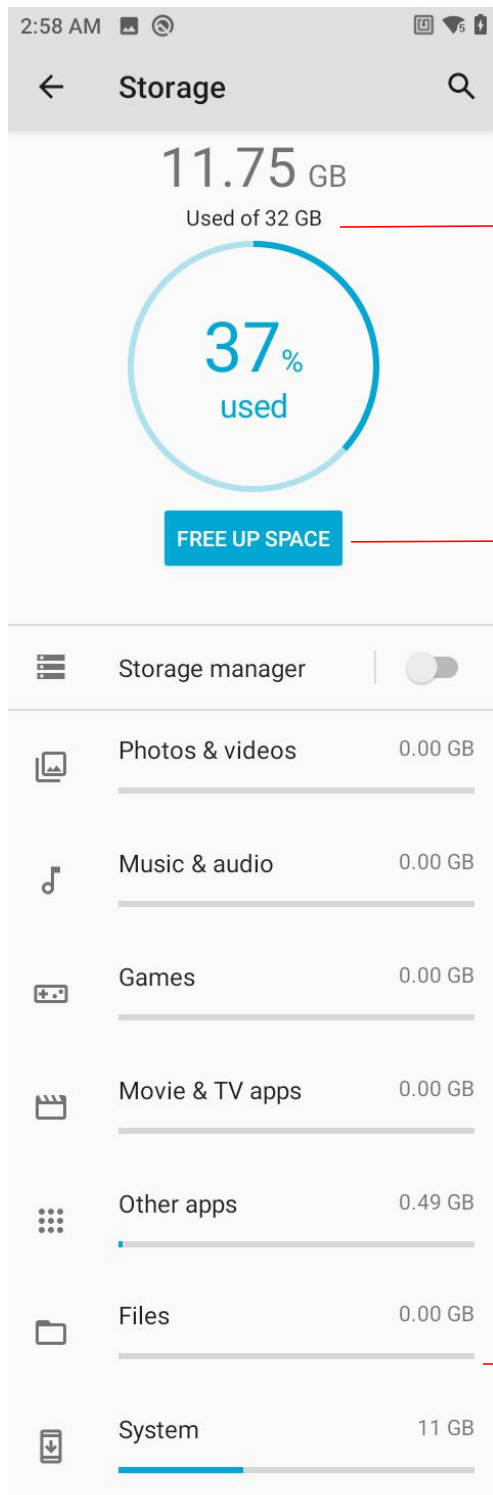

On the Home screen, swipe up from the bottom of the screen and touch  and choose Storage.

used of 32 GB.

Touch "FREE UP SPACE".

Show all items
Hide recent items.

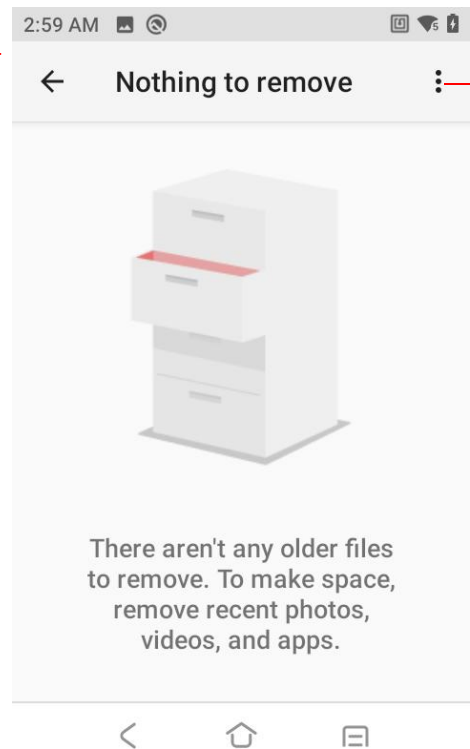

Slide up and down to view storage information of different types.

Privacy

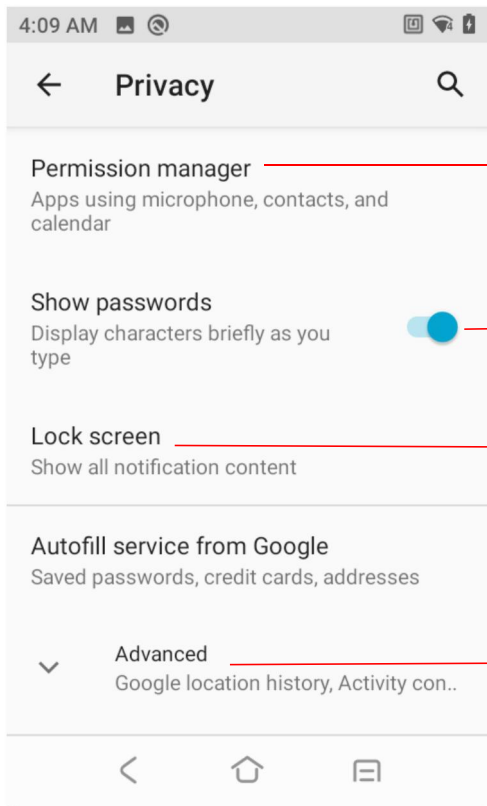

View or modify application permissions.

Display characters briefly as you type.

Show all notification content;
Don't show notification at all.

Google location history, Activity controls,
Ads, Usage & diagnostics.

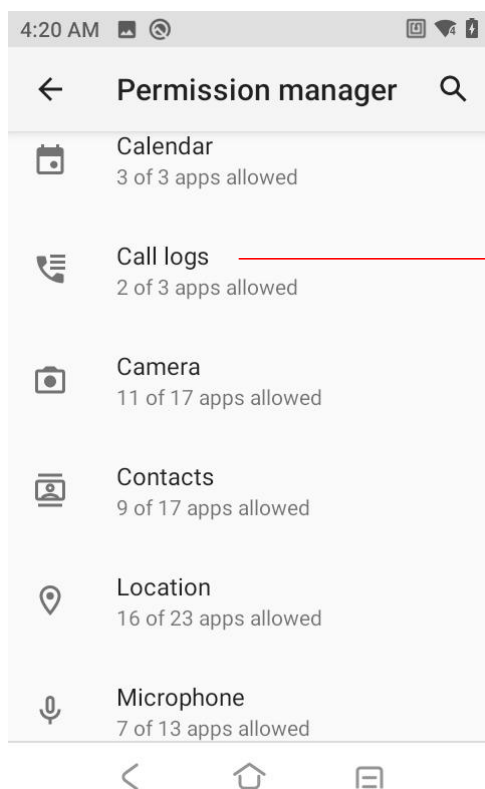

You can view the applications that have been allowed or denied this permission and click the application you want to modify.

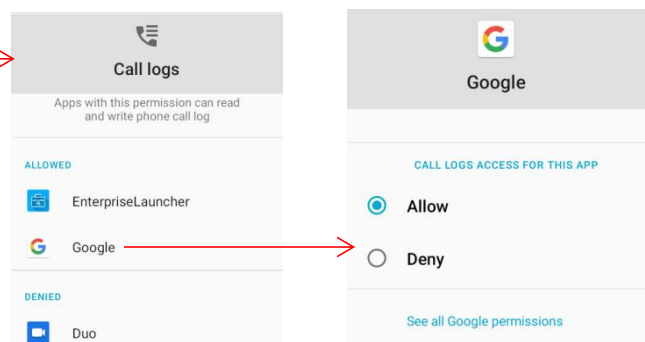

Example: modify whether the Google application allows call logs permission.

Location

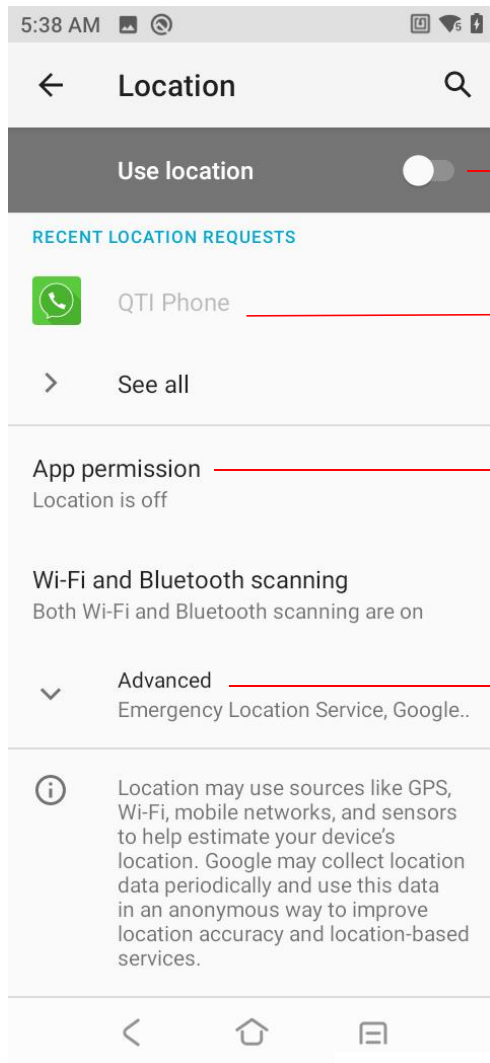

Enable location service.

View the software that recently applied for location information.

View or modify application location permissions.

Emergency Location Service;
Google Location Accuracy;
Google Location History;
Google Location Sharing.

Modify application location permissions.

App permission
Location is off

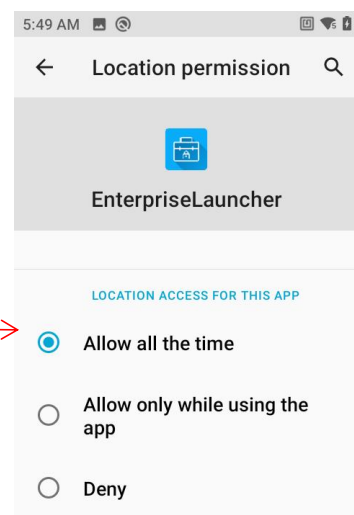
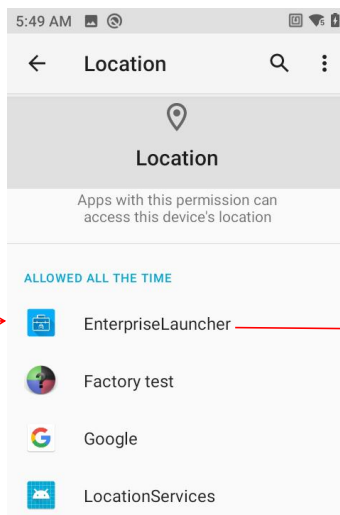

Security

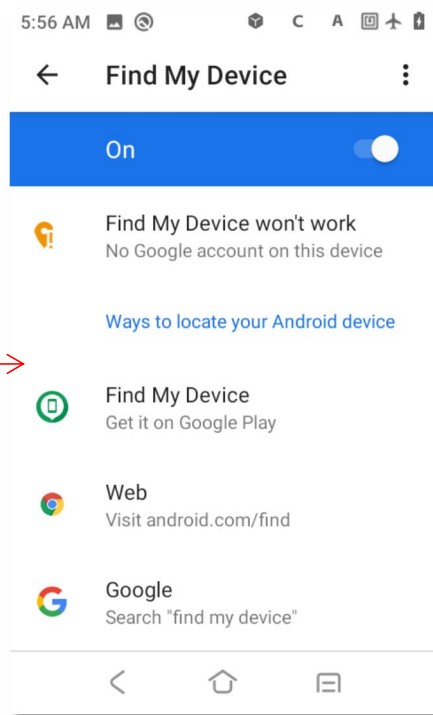
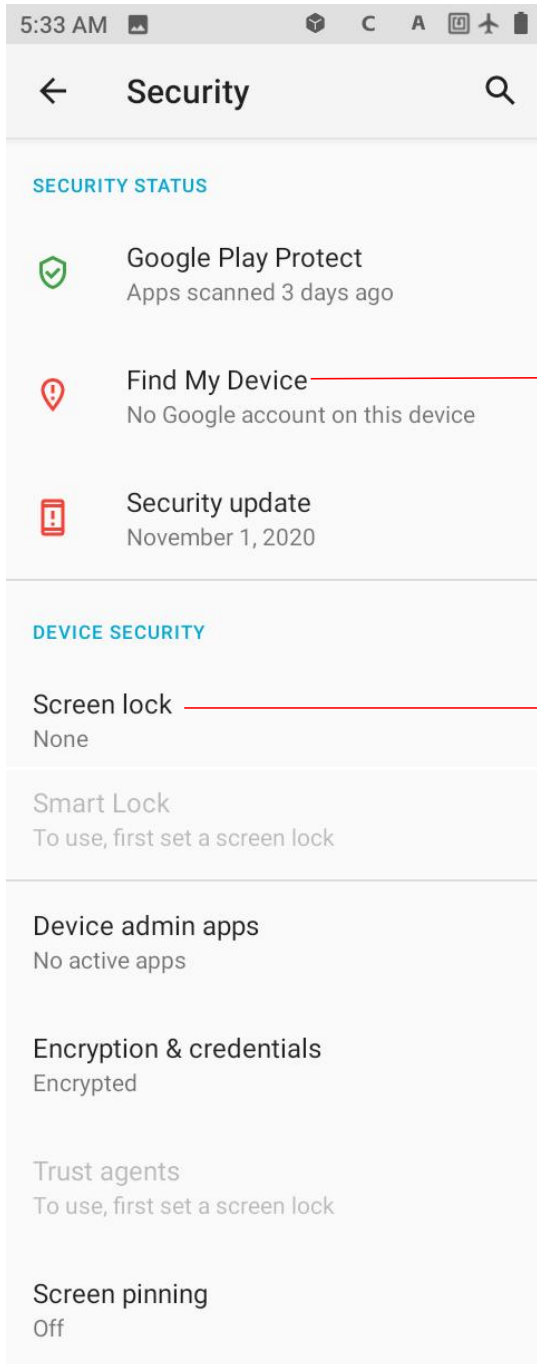

Find My Device helps you locate this device remotely. It also helps you keep your data safe if the device is lost.

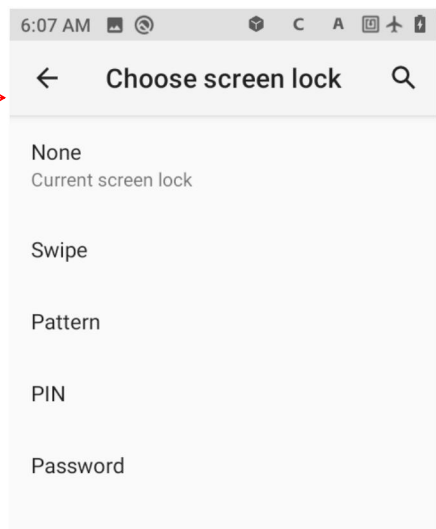

Accounts

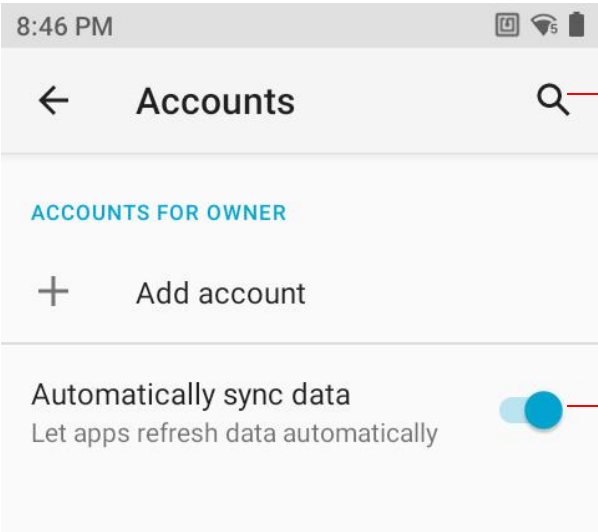

Search accounts.

Turn on automatically sync data.

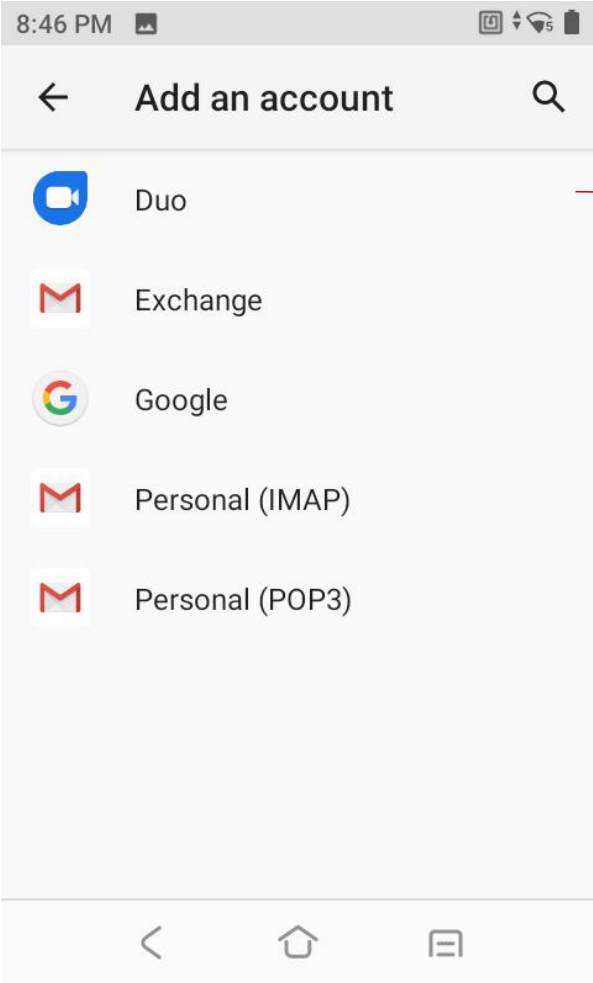

Click "Add Account" to create an account.

Accessibility

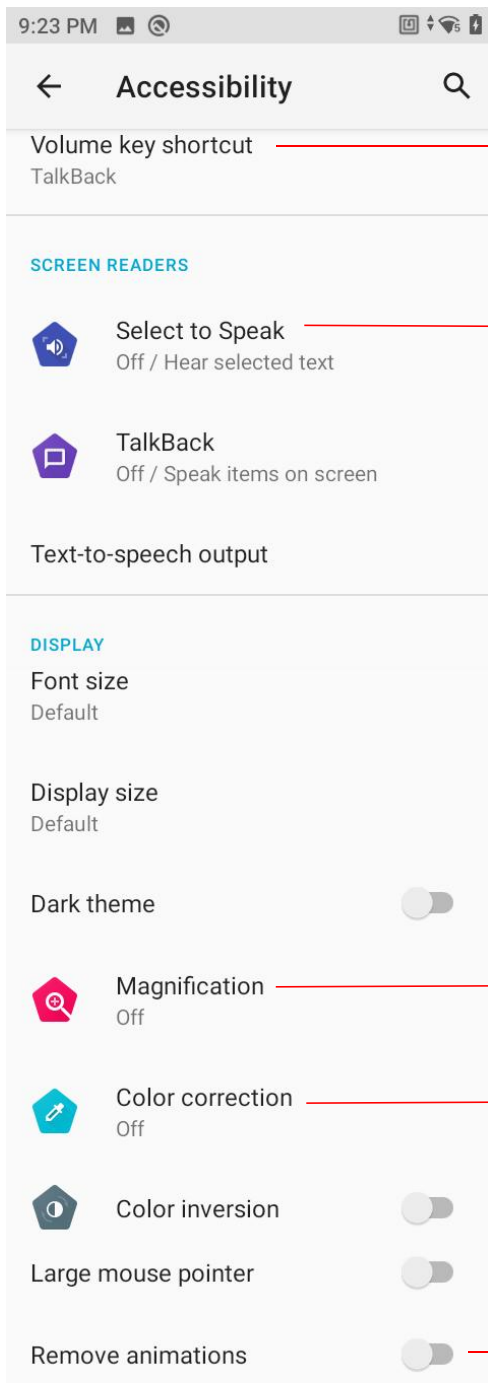

Use the volume key as a shortcut to enable accessibility.

When "Select to speak" is on, you can tap specific items on your screen to hear them read aloud.

Text-to-speech output—Preferred engine.

Magnify with triple-tap;
Magnify with shortcut.

Color correction-correction mode:
Deuteranomaly (red-green);
Protanomaly (red-green);
Tritanomaly (blue-yellow).

There is no animation when the page is switched.

Accessibility

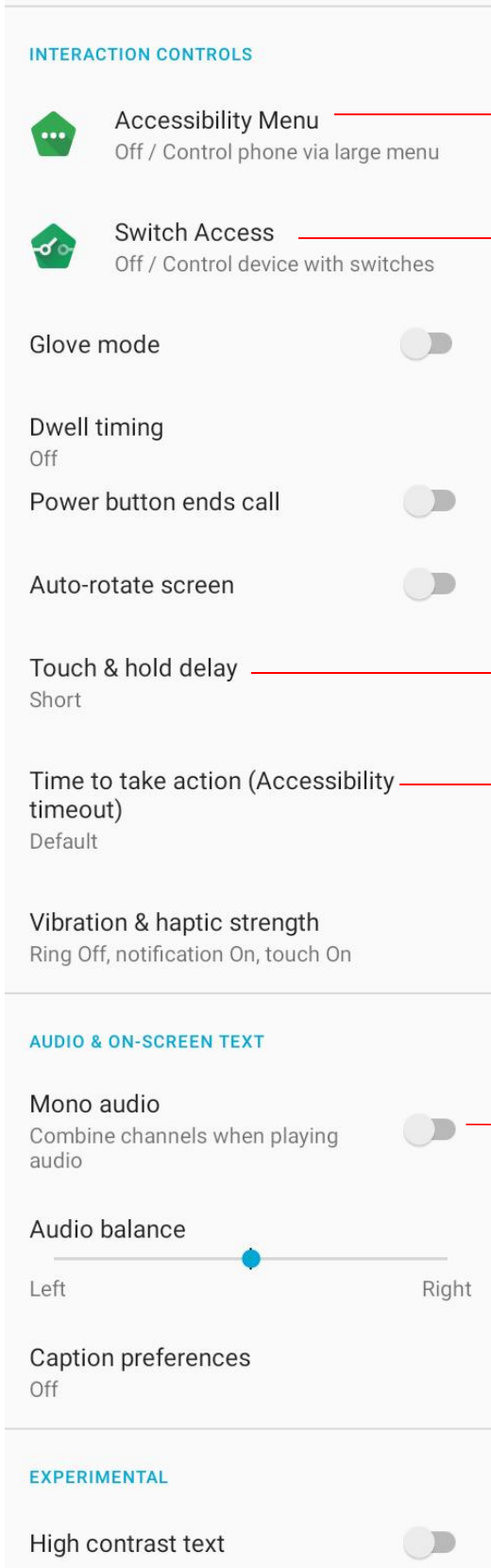

The Accessibility Menu provides a large on-screen menu to control your device.



Switch Access lets people with motor impairments control device and tablets using one or more switches.

Short; Medium; Long.

Choose how long to show messages that ask you to take action, but are visible only temporarily.

Ring vibration; Notification vibration; Touch feedback.

Combine channels when playing audio.

Digital Wellbeing & parental controls

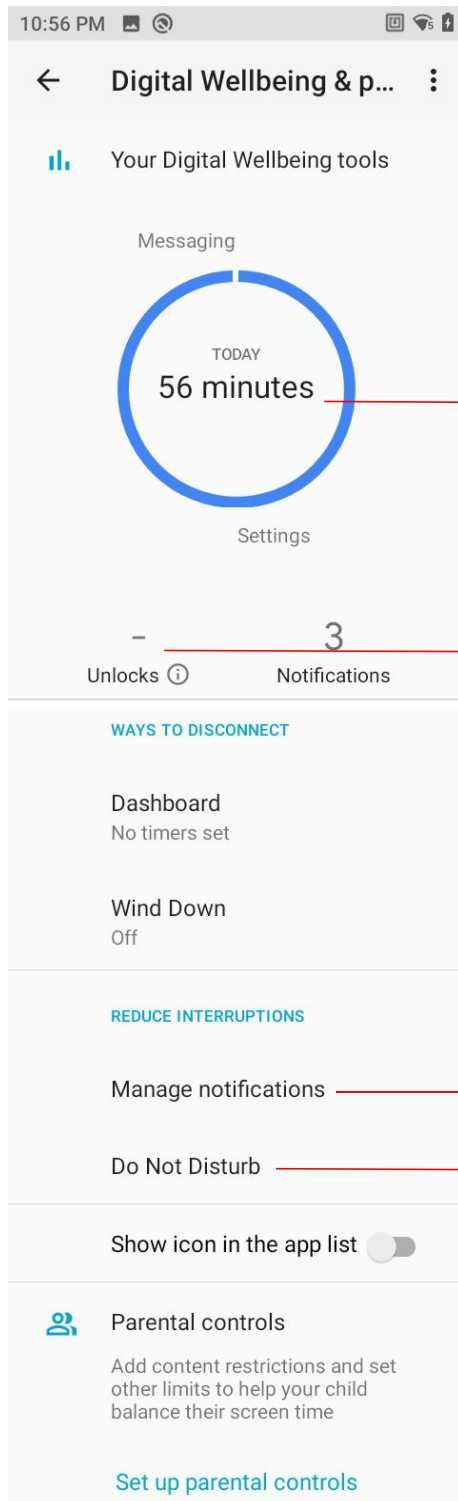

- Send feedback
- Beta program
- Turn off usage access
- Privacy Policy
- Terms of Service
- Open-source licenses

Screen time.

Unlock information isn't available for devices without screen locks.

Set daily timers for most apps.

Manage App notification.

Do not Disturb.

System

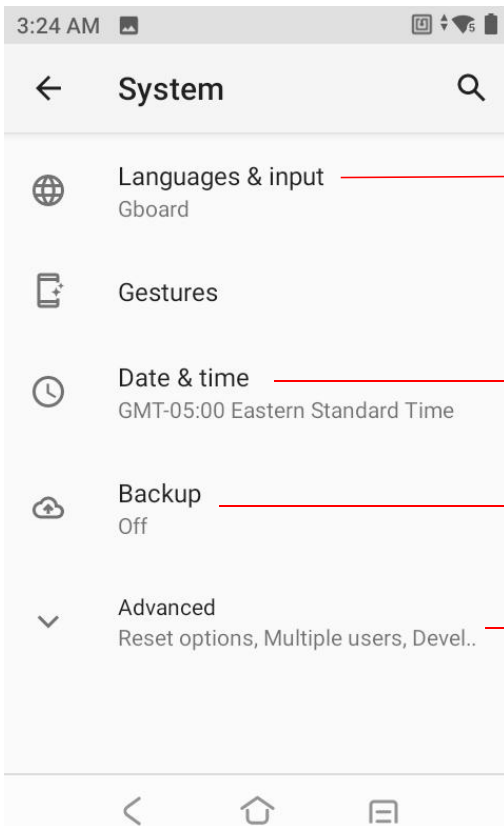

Languages; Keyboards.

Modify the date and time.

Backup: Easily restore your data or switch device at any time.

Reset options, Multiple users, Developer options, System update, Hardware Feedback.

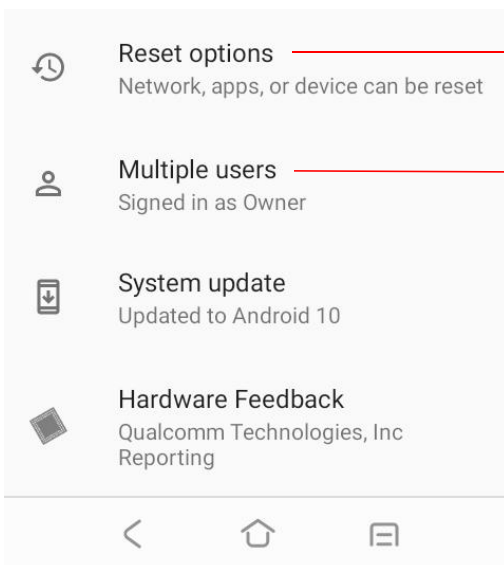

Reset Wi-Fi, mobile & Bluetooth; Reset app preferences, Erase all data (factory reset).

Edit multiple users.

Language & input

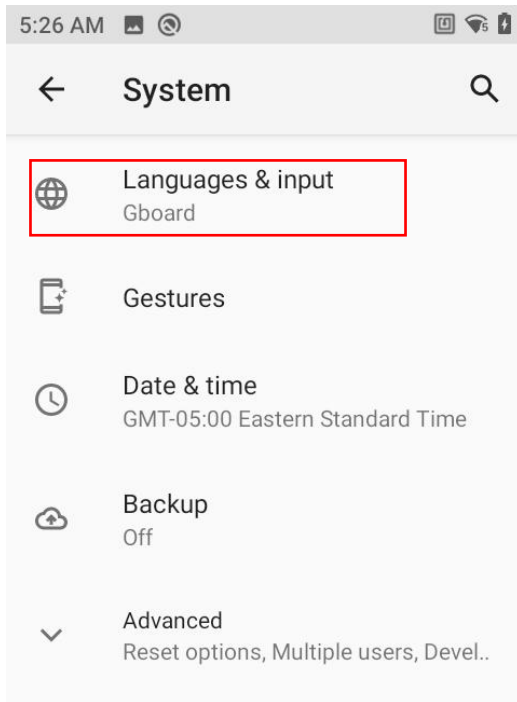

Touch "Settings-System-Language & input".

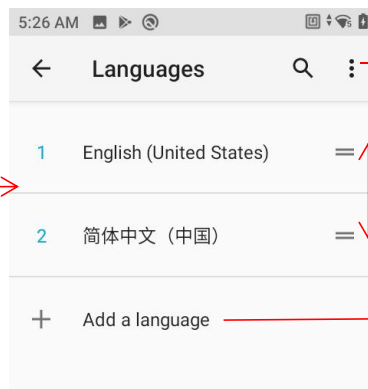
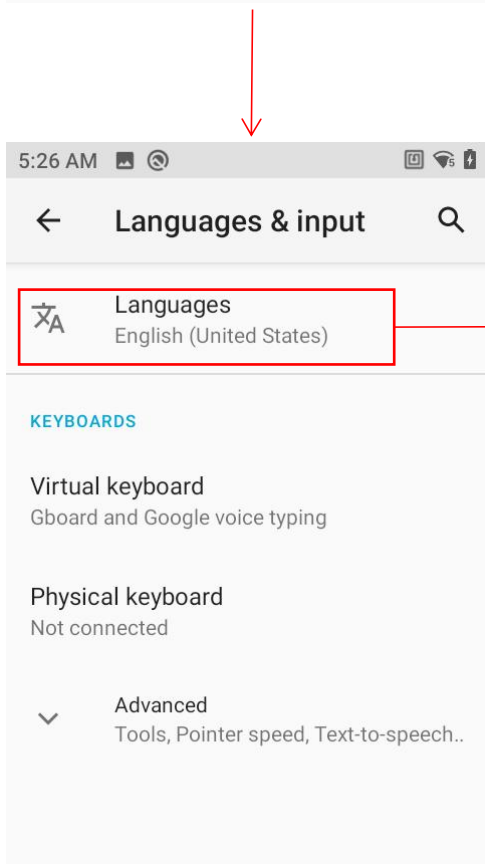

Remove language.

Drag the language you want to set to the top.

Add language.

Data & time

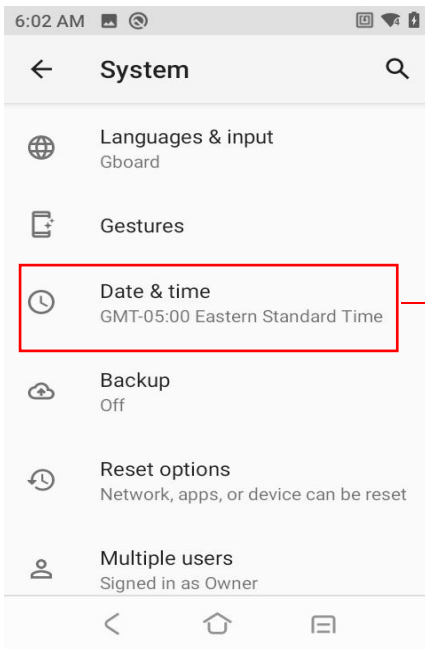

Touch " Settings-System-Data & time".

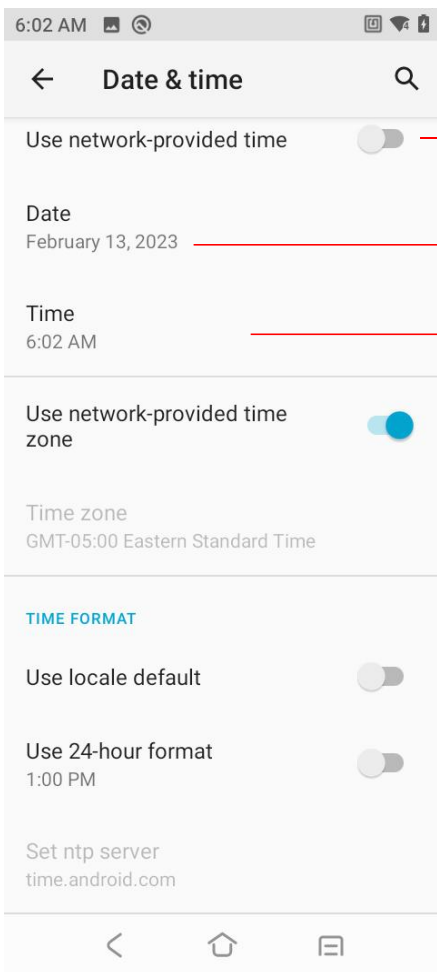

If you want to manually change the date and time, first turn off "Use network-provided time".

Touch to set Data.

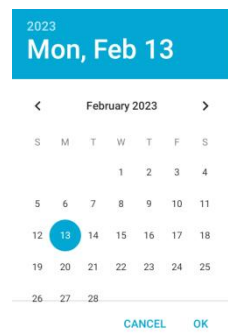

Touch to set Time.

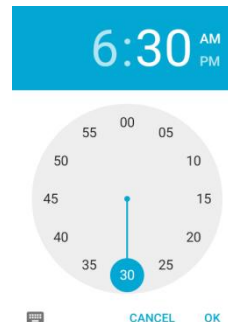

About phone

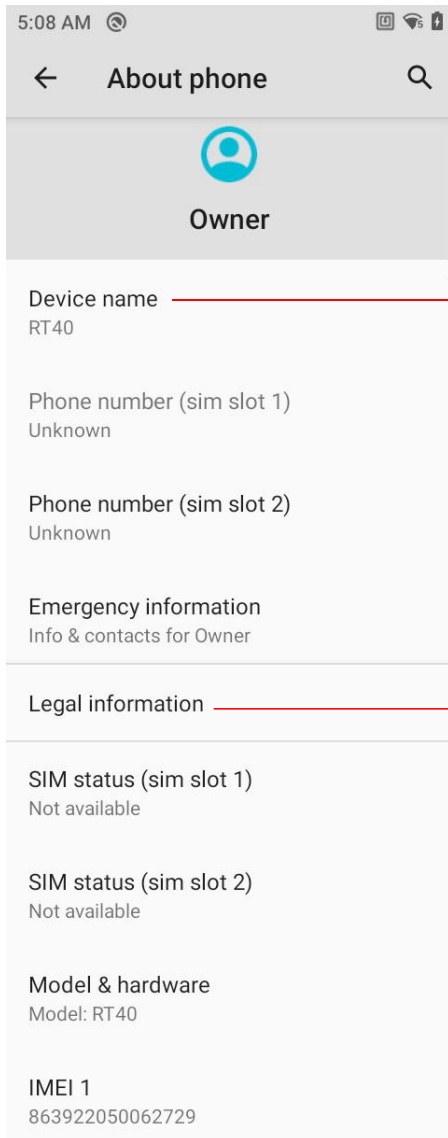

Touch change "Device name".

Third-party licenses, Google legal, System WebView licenses, Wallpapers.

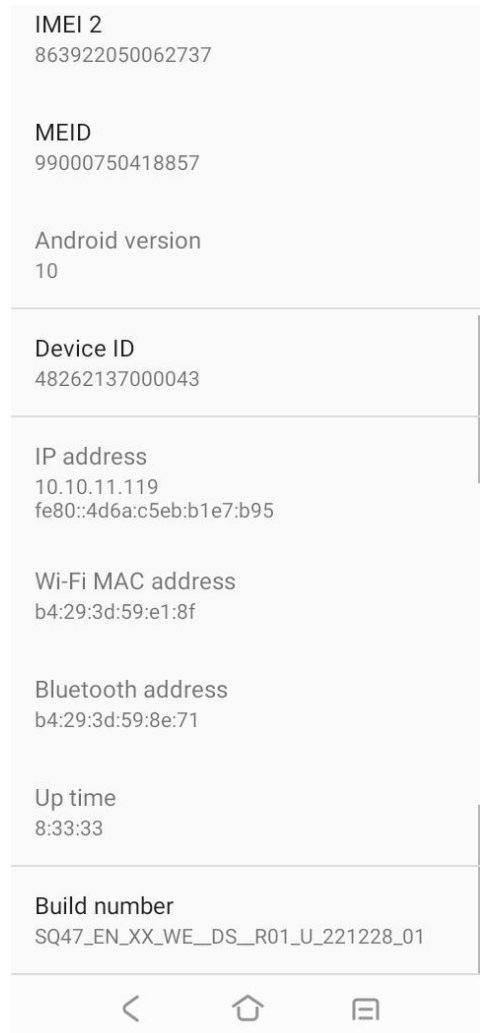

Scanner Settings

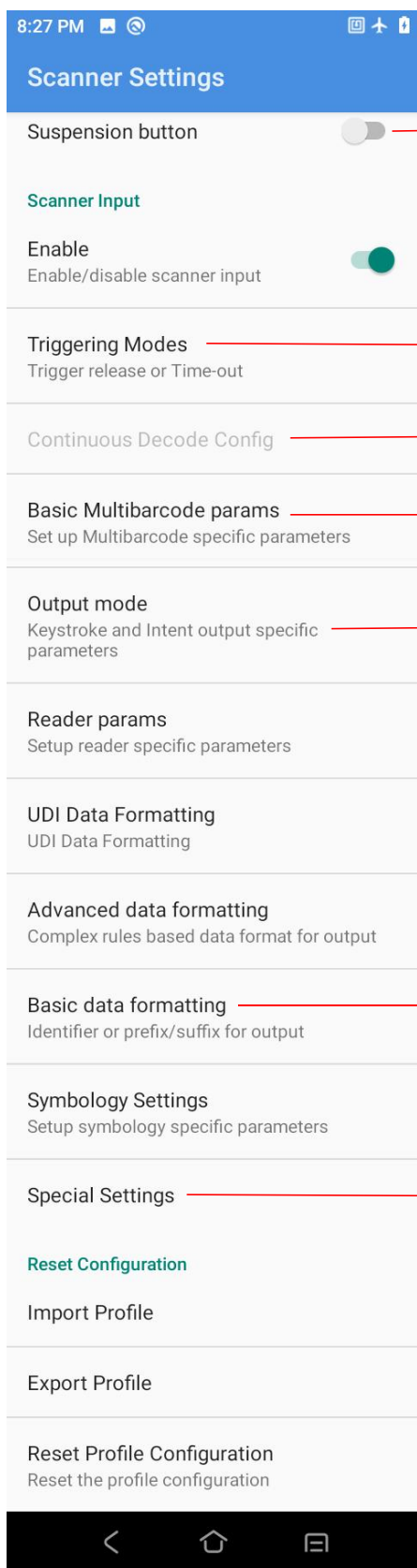

Suspension button: Open the virtual key scanning tool on the desktop--USCAN, which is available for dragging at will and touching to simulate the key scanning function.

Decode or Time-out, KeyDown start, Again KeyDown stop, Trigger release or Time-out.

To enable this configuration, select "KeyDown start, Again KeyDown stop" in "Triggering Modes".

Set up Multibarcode specific parameters.

Output mode: Intent output, Keystroke output, Keystroke and Intent output.

Upon access of bar codes, the system may be available for additional functions: Formatting, Prefix, Suffix, Formatting, Substitute, Delete Non-printing Control Character, App Identifier, or Code Id Type.

Characters delay, Key event delay.

ScanWedge Profile

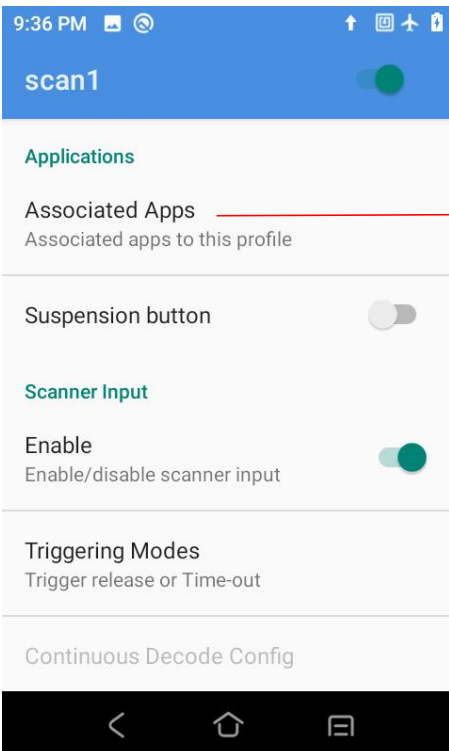
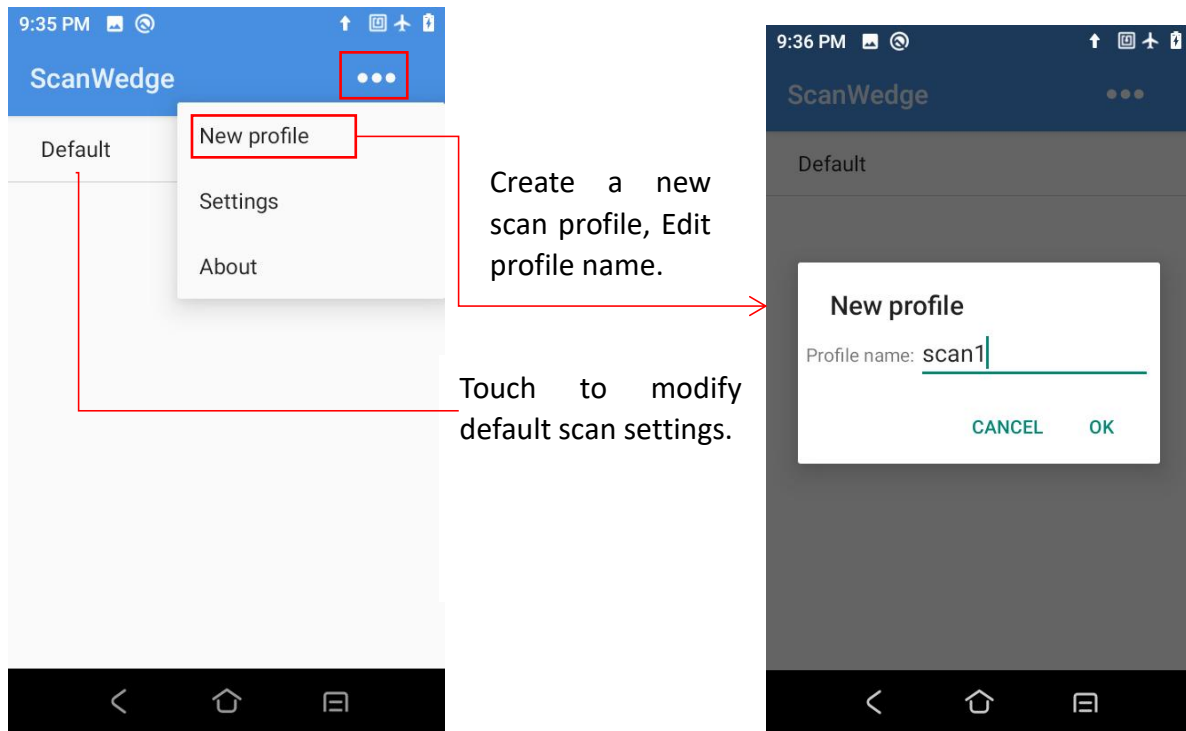





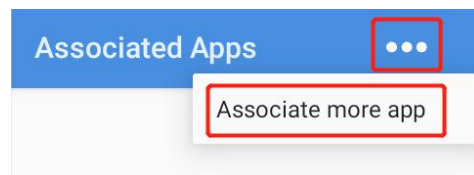





Modify the Settings in the new scan configuration file.

Associated apps to this profile.



Feature Settings

FeatureSettings	
<p>Status bar pull down Enable / disable the status bar drop-down function. After disabled, the function of status bar cannot be modified</p> 	<p>The default is "on", if disabled, the status bar function cannot be modified.</p>
<p>Virtual key Enable/disable the virtual keys under the touch screen. Click is not effective.</p>	<p>The default is "on", click on the virtual key at the bottom of the screen does not take effect after disabling the corresponding virtual switch.</p>
<p>Hide navigation bar After hiding the navigation bar, swipe up the bottom of the screen to call up the navigation bar.</p> 	<p>The default is "off", select "on" if you want to hide the navigation bar at the bottom of the screen.</p>
<p>Input Method Editor(IME)pops.. Enable/Disable IME pops up automatically for data entry by the user</p> 	<p>The default is "on", select "Disable this function" if you want to disable automatic pop-up of the input method during code scanning.</p>
<p>Disable Input Method IME activates</p> 	<p>The default is "on", select "off" if you want to enable the input method editor.</p>
<p>Soft keyboard floating window A suspension button is displayed on the screen to turn the soft keyboard on or off</p> 	<p>The default is "off", a suspension button  is displayed on the screen to turn the soft keyboard on or off.</p>
<p>Show scan suspension button A suspension button is displayed on the screen instead of the scan button.</p> 	<p>The default is "on", a suspension button is displayed on the screen instead of the scan button.</p>
<p>Automatic call recording After enabling, all calls are automatically recorded and saved local sdcard/EnterpriseDesktop/record</p> 	<p>The default is "off", all call recordings of the device will be automatically saved to local after turning on, which is convenient for information traceability.</p>
<p>Three finger screenshots Eable/disable the three finger screenshots</p> 	<p>The default is "off", take a screenshot by swiping up or down on the screen with three fingers simultaneously after turning on.</p>
<p>Screen Pinning You can use screen pinning to keep the current screen in view until you unpin.(Power+Volume up)</p> 	<p>The default is "off", the shortcut key ("power" key and "volume +" key pressed simultaneously) can fix the current screen after turning on, and at this time, you can only view the screen content, not to operate; if you want to cancel the fixed, press the shortcut key again.</p>
<p>Default Launcher Modify the default Launcher of the system and boot to complete the selected desktop.</p>	

Remap Key

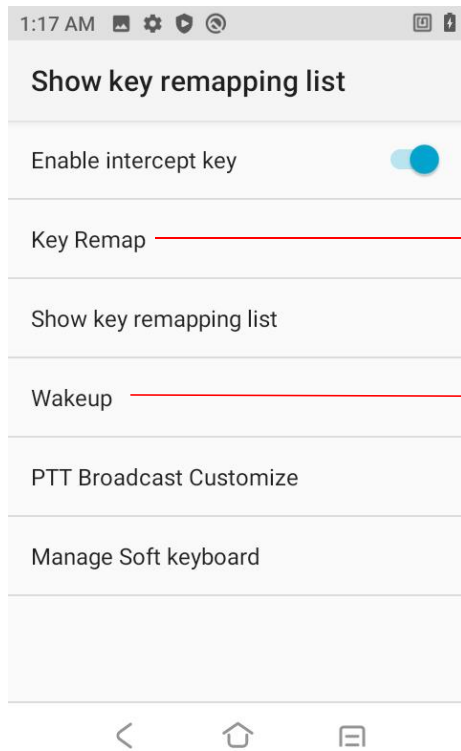

Key Remap can keymap all physical keys except the power key, and the mapped keys will be given a new key value, that is, pressing the button can achieve customized functions.

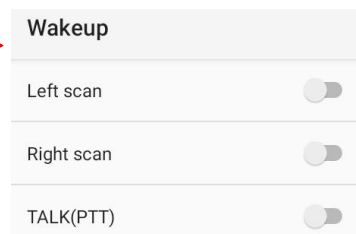

Open the corresponding key switch, which can be used to wake up the screen.

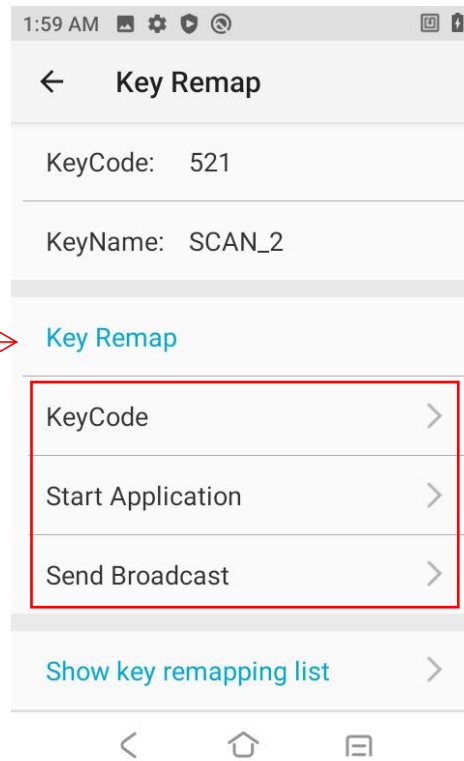
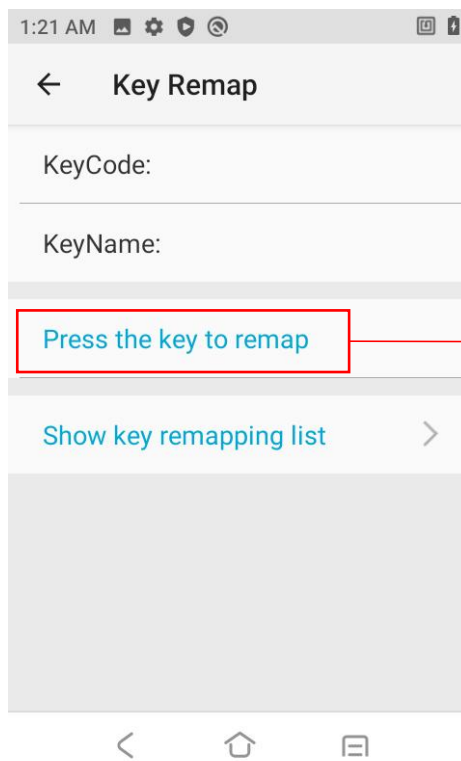

Docking Station

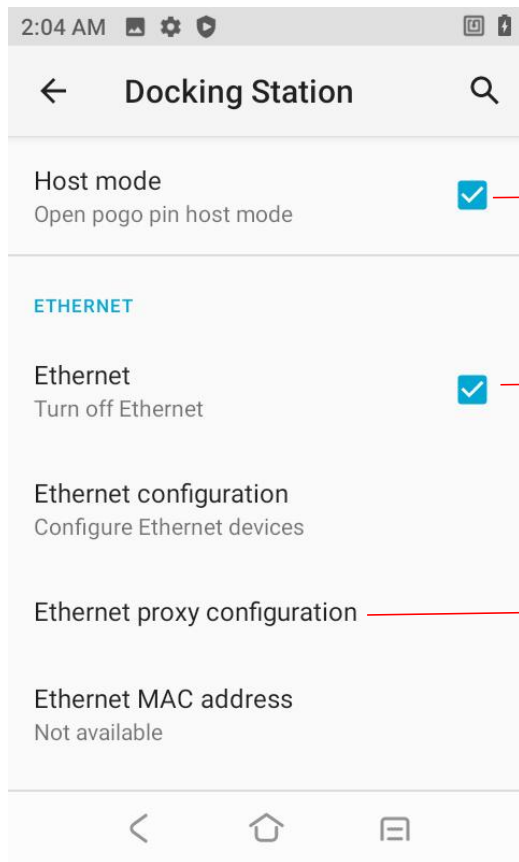

Open Host mode.

Open Ethernet.

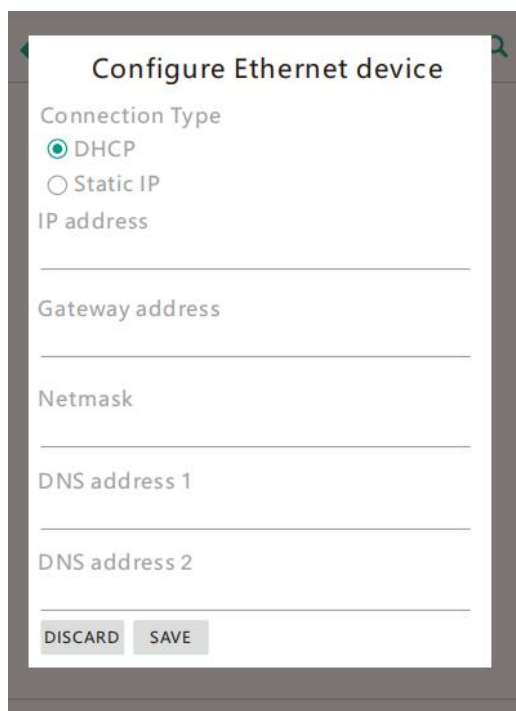
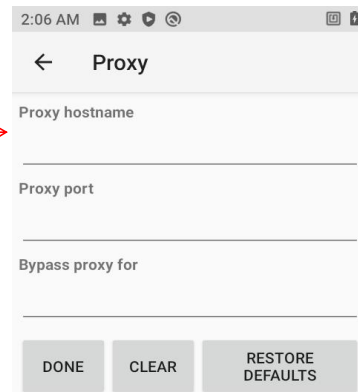

Ethernet Configuration

Application

Application Window

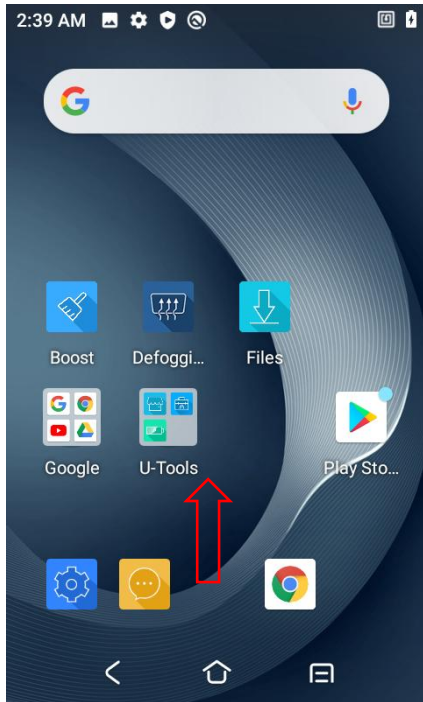

On the Home screen, swipe up from the bottom of the screen.

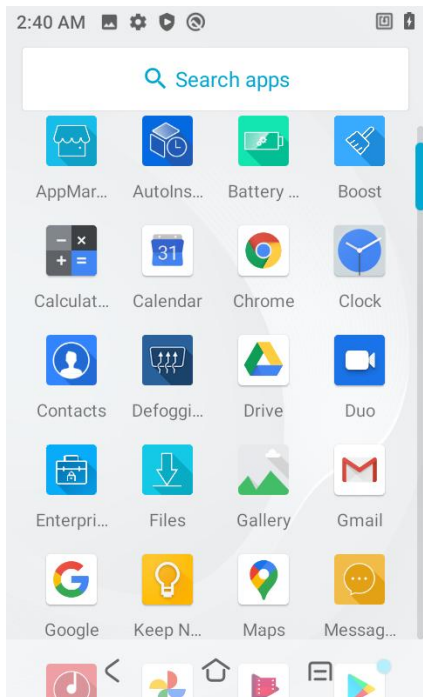

Applications Window

Slide the APPS window up or down to view more app icons. Touch an icon to open the app.

Switching Between Recent Apps

To switch between recent apps:

1. Touch . A window appears on the screen with icons of recently used apps.

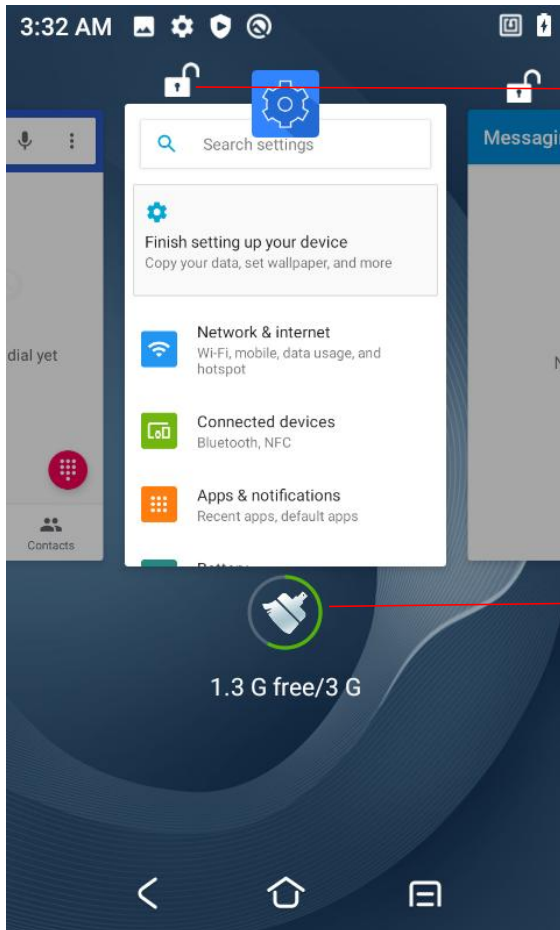











Touch this icon to not close the software when the lock is closed.







If you close all of the apps, then touch the Brush icon. In this case, the locked app will not be closed.

2. Slide the apps displayed left and right to view all recently used apps.
3. Swipe up or down to remove app from the list and force close the app.
4. Touch the software page to open the application and touch the blank area to return to the current screen.





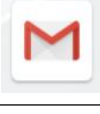
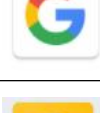
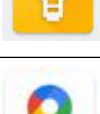
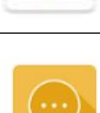
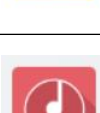
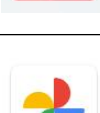







Apps Icon

Icon	Description
	<p>App Market-Download apps defined in the cloud management platform.</p>
	<p>Battery-View the battery level, charging status, battery health Level, and battery information.</p>
	<p>Boost-One click to clean up memory and free up storage space.</p>
	<p>Calculator-Provide basic and scientific calculating functions.</p>
	<p>Calendar-View and manage calendar events.</p>
	<p>Camera-Take photos and record videos.</p>
	<p>Chrome-Access the network.</p>
	<p>Clock-Set the alarm and timer.</p>
	<p>Contacts-Manage contact information.</p>
	<p>Defogging-Click to open the defogging mode to remove the fog on the scanning head.</p>

Applications

	Drive -Allows offline access to users' files stored and share them with others.
	DUO -For video calls.
	Enterprise Launcher -Restricts access to programs and settings on the device, enabling control of the device and simplifying the enterprise desktop.
	Files -List all the files downloaded from the device.
	Gallery -For managing and viewing photos and videos.
	Gmail - Receive and send e-mails.
	Google -Access the network.
	Keep Notes -For easy creation of articles, pictures, voice notes, and timely uploading to the cloud for saving.
	Maps -Browse maps, search for locations, check bus and car routes, and view real-time traffic status.
	Messaging -Receive and send SMS and MMS.
	Music -Managing audio files.
	Photos -View or edit photos in the device.

Applications

	Google Play -Allows users to browse, download and use applications published by Google.
	Play Store -Used to find the latest Android apps, games, movies and more.
	Phone -Dial a phone number for voice communications.
	Scanner -Test the engine module of scanner, Images can be displayed in real time.
	Scanner -Test the engine module of scanner.
	ScanWedge - Allows to modify the default settings for scanning and to create new scan settings to be applied to custom software.
	Settings -Use to configure the device.
	Sound Recorder -Record audio files.
	Videos -Manage and watch local videos.
	WiFi Diagnosis -Real-time analysis and troubleshooting of WiFi to pinpoint problems.
	YouTube -Used to download, watch and share videos or clips.
	YT Music -Used to play audio files from this unit or stored in Micro SD Card.

App Market

App Market - Classification

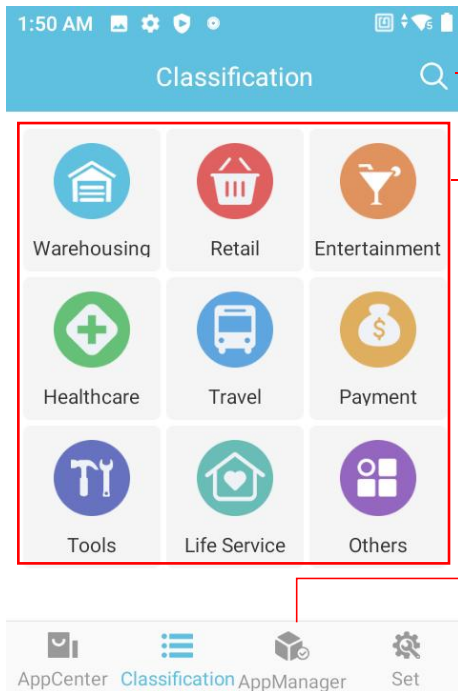

Search application.

Classification-Click the type of APP you want to download.

View the downloading and installed apps.

App Market - Set

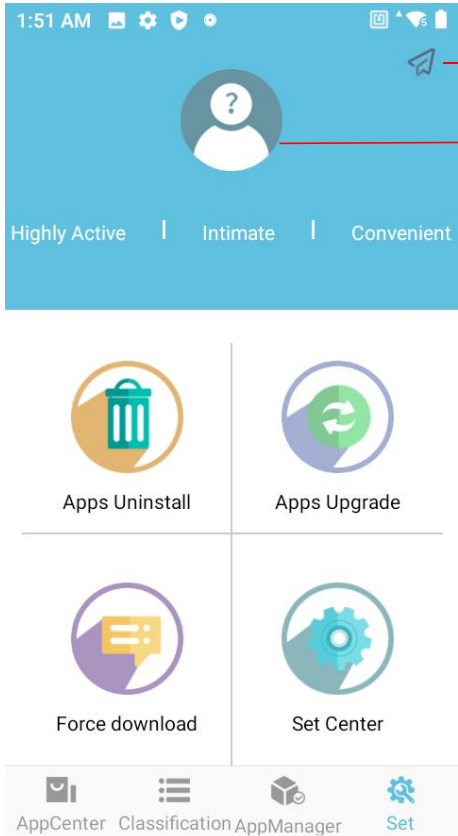

Message Center.

Personal login.

Clock

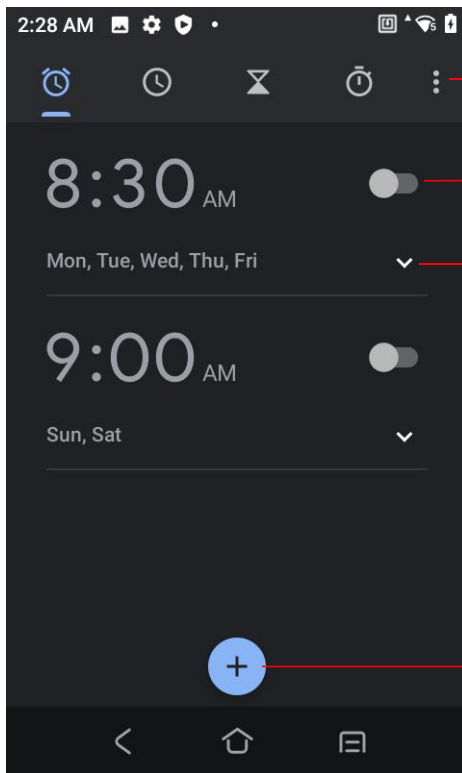

Screen saver, Settings, Send feedback, Help.

Slide on the alarm.

Tap the icon to set the alarm.

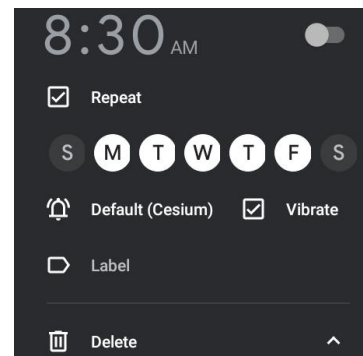

Add a new alarm clock.

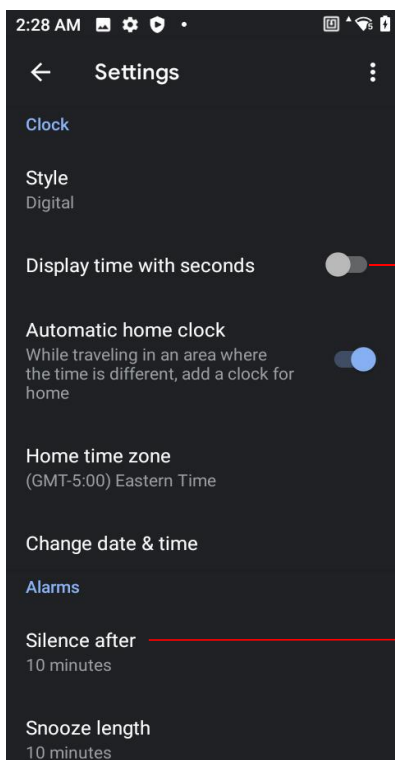

Touch turn on display time with seconds.

Set the alarm time.

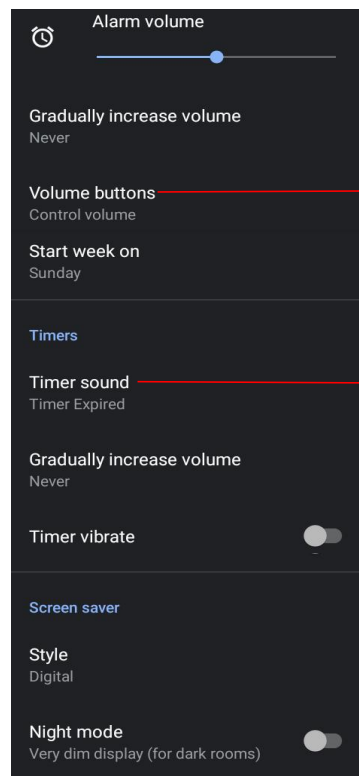

Control volume, snooze, Dismiss.

Click to select Timer Sound.

Contacts

9:03 PM

Select all, Choose to share or delete contacts.

Contacts

Clara Oswald

Jane Smith

John Smith

Long press a contact to share or delete it.

1

Create a new contact.

9:03 PM

Create new contact

SAVE

9:32 PM

John Smith

153 6855 8685
Mobile

12345678@qq.com
Home

Send a message to the contact.

Make a call to the contact person.

Send an email to the contact.

Enterprise Launcher

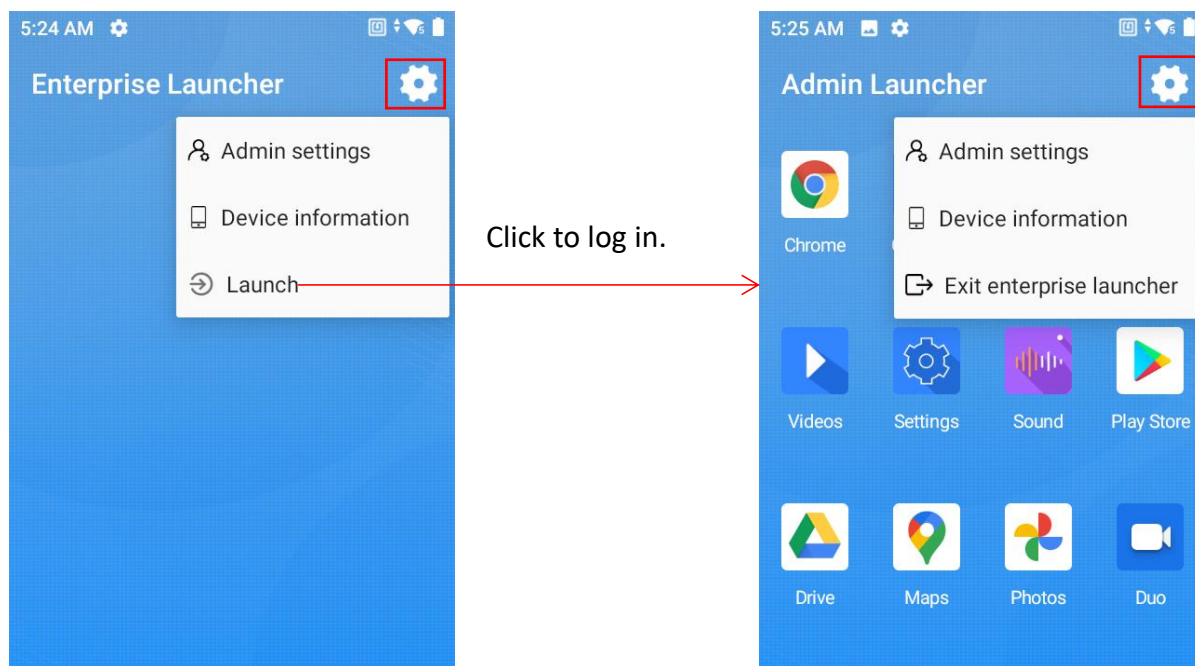

The administrator screen displays all applications on the device. You can install and uninstall applications, view application details and so on.

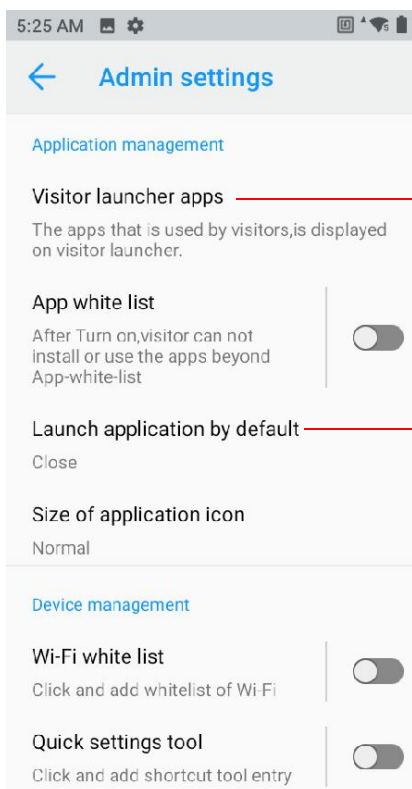

Select the application to be displayed on the user's desktop.

Make the required APP open by default after startup.

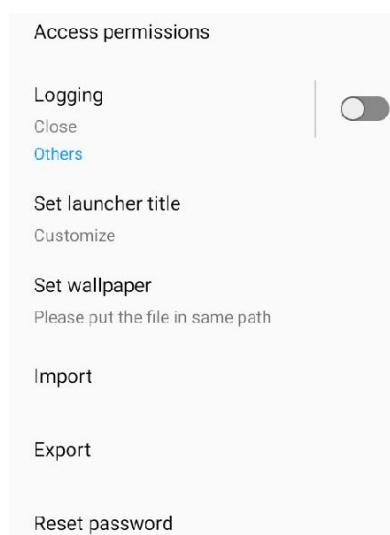

Messaging

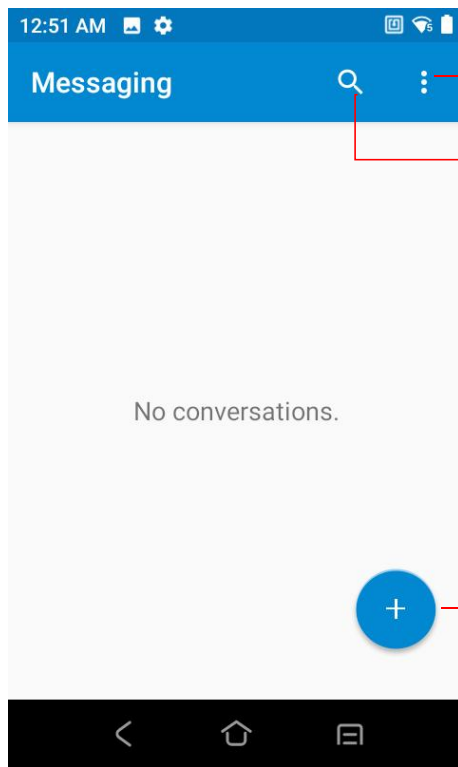

Settings.

Searching for messages.

Touch to send a new message.

New message edit page

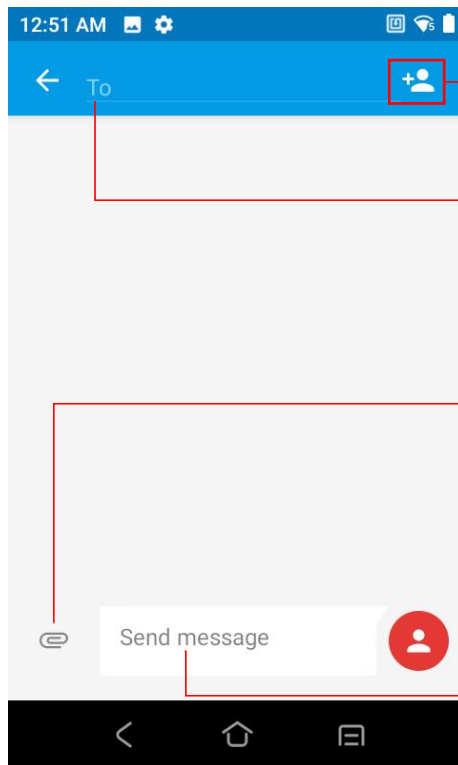

Select the contact to send the message.

Enter a phone number to send a message.

Choose sending subject, pictures, videos and so on.

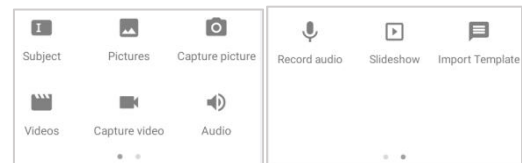

Edit message box.

Maintenance and Troubleshooting

Maintenance Equipment

For trouble-free service, observe the following tips when using the RT40:

- Do not scratch the screen of the RT40.
- The touch-sensitive screen of the RT40 is glass. Do not drop the RT40 or subject it to strong impact.
- Protect the RT40 from temperature extremes. Do not leave it on the dashboard of a car on a hot day, and keep it away from heat sources.
- Do not store or use the RT40 in any location that is dusty, damp, or wet.
- Use a soft lens cloth to clean the RT40. If the surface of the screen becomes soiled, clean it with a soft cloth moistened with a diluted window-cleaning solution.

Long-Term Storage

When storing the device for long periods of time, ensure that the battery has at least 50% charge and is stored at -40~70°C.

Cleaning Instructions

Do not apply the liquid directly to the device. Dampen a soft cloth or use pre-moistened wipes.

Do not wrap the device in the cloth or wipe, but gently wipe the unit. Be careful not to let liquid pool around the display window or other places. Allow the unit to air dry before use.

Cleaning Equipment

Cleaning Materials Required

Alcohol wipes, Lens tissue, Cotton-tipped applicators, Isopropyl alcohol, Can of compressed air with a tube.

Cleaning Frequency

Because mobile devices are used in different environments, the frequency of cleaning is determined by the user. Customers can decide how often to clean as needed. However, if used in a dirty environment, it is recommended to clean the camera window regularly for optimal performance.

Cleaning the RT40

Housing: Using the alcohol wipes, wipe the housing including the buttons.

Display: The display can be wiped down with alcohol wipes, but care should be taken not to allow any pooling of liquid around the edges of the display. Immediately dry the display with a soft, non-abrasive cloth to prevent streaking.

Camera and Exit Window: Wipe the camera and exit window periodically with lens tissue or other material suitable for cleaning optical material such as eyeglasses.

Connector Cleaning:

1. Connector Cleaning;
2. Dip the cotton portion of the cotton-tipped applicator in isopropyl alcohol.
3. Rub the cotton portion of the cotton-tipped applicator back and forth across the connector. Do not leave any cotton residue on the connector.
4. Repeat at least three times.
5. Use the cotton-tipped applicator dipped in alcohol to remove any grease and dirt near the connector area.
6. Use a dry cotton-tipped applicator and repeat steps 4 through 6.

Maintenance and Troubleshooting

7. Spray compressed air on the connector area by pointing the tube/nozzle about ½ inch away from the surface.8. Inspect the area for any grease or dirt, repeat if required.

Cleaning Cradle Connectors:

1. Remove the DC power cable from the cradle.
2. Dip the cotton portion of the cotton-tipped applicator in isopropyl alcohol.
3. Rub the cotton portion of the cotton-tipped applicator along the pins of the connector. Slowly move the applicator back and forth from one side of the connector to the other. Do not leave any cotton residue on the connector.
4. All sides of the connector should also be rubbed with the cotton-tipped applicator.
5. Spray compressed air in the connector area by pointing the tube/nozzle about ½ inch away from the surface.
6. Remove any lint left by the cottontipped applicator.
7. If grease and other dirt can be found on other areas of the cradle, use a lint-free cloth and alcohol to remove them.
8. Allow at least 10 to 30 minutes (depending on ambient temperature and humidity) for the alcohol to air dry before applying power to cradle.If the temperature is low and humidity is high, a longer drying time is required. Warm temperature and dry humidity require less drying time.

Troubleshooting

The following tables provides typical problems that might arise and the solution for correcting the problem.

Problem	Reason	Solution
Press the power key but RT40 does not work.	The battery is not charged.	Charge the battery.
	The system crashes.	Execute resetting.
The battery is not charged	The battery breaks down.	Replace the battery.
	The battery's temperature is exceptional.	Contact for technical support.
During data communication via Wi-Fi, no data are transferred or not all data are transferred.	Wi-Fi communication is not enabled.	Enable Wi-Fi communication.
	The device is out of the range of the access point.	Move closer to the access point.
During data communication via Bluetooth, no data are transferred or not all data are transferred.	Bluetooth communication is not enabled.	Turn on Bluetooth communication.
	The device is out of the signal range of another Bluetooth device.	Move within 10m (32.8ft) range of another device.
No sound.	Volume setting is too low or turned off.	Adjust volume.
RT40 is off.	RT40 is at inactive state.	Not use for a while, the display will automatically turn off. Set the duration to be longer, such as 15 s, 30 s, 1 min, 2 min, 5 min, 10 min or 30 min.
	The battery is depleted.	Charge the battery.

Maintenance and Troubleshooting

Tapping a window button or icon but fail to trigger the corresponding function.	The device does not respond.	Reset the device.
A message pops up, indicating that RT40's storage is full.	Too many files are saved in RT40.	Delete unused memos and records. If necessary, save such records in the host (or use SD Card as additional memory).
	Too many apps are installed in RT40.	Uninstall unused apps in RT40 to recover storage capacity.
RT40 fails to decode while reading a bar Code.	The bar code is unreadable.	Check the barcode is not damaged.
	The distance between the laser scanning window and bar code is wrong.	Put RT40 within proper scanning range.
	The bar code type is not checked, or bar code length is wrong.	Set RT40 to accept the scanned bar code type.
	Battery low.	If the scanner stops emitting a laser beam upon a trigger press, check the battery level. When the battery is low, the scanner shuts off before the RT40 low battery condition notification. Note: If the scanner is still not reading symbols, contact the distributor or the Global Customer Support Center.
Cannot unlock RT40	User enters incorrect password.	If the user enters an incorrect password eight times, the user is requested to enter a code before trying again. If the user forgot the password, contact system administrator.
RT40 cannot find any Bluetooth devices nearby.	Too far from other Bluetooth devices.	Move closer to the other Bluetooth device(s), within a range of 10 meters (32.8 feet).

Maintenance and Troubleshooting

	The Bluetooth device(s) nearby are not turned on.	Turn on the Bluetooth device(s) to find.
	The Bluetooth device(s) are not in discoverable mode.	Set the Bluetooth device(s) to discoverable mode.

Precautions

1. Read all information in this guide before using the device to ensure safe and proper operation.
2. Please use the accessories that have been approved by this manufacturer and correspond to this model. Use of any power source, charger, battery, etc. that has not been approved by this manufacturer may cause a fire, explosion, or other hazards.
3. Please use device and accessories within the specified temperature range. Equipment failure may occur when the ambient temperature is too high or too low.
4. Do not disassemble the product and its accessories. If the equipment or any of its components are not working properly, consult the after-sales service of the company promptly, or send the equipment to the after-sales service outlet for testing and maintenance.
5. The battery is made from a flammable and explosive material. Do not disassemble, squeeze, drop and make any other destructive operations on the battery. Do not place the battery in high temperatures.
6. Disposal of used batteries is subject to local relevant documents or policies regarding disposal of used batteries.

Warranty Policy

Thank you for using Urovo intelligent terminal series products. In the situation of quality problems, which arise from raw materials or production processes, during normal use of purchased products, Urovo Technology Co., Ltd. will be responsible for free maintenance within one year from the date of purchase.

The company may provide repairs due to the user's failure to use the product according to the provided instructions of the product. However, corresponding service fee and component fee will be charged.

Warranty regulations:

1. Under normal circumstances, the warranty period of the device is 12 months (3 months for accessories), subject to the sales agreement.
2. During the product warranty period, under the normal use conditions (determined by our technical staff), the user will be entitled to a free warranty for damaged or faulty warranty parts.
3. During the warranty period, faults caused by repair, disassembly or modification of the product by a personnel other than our company, improper installation, improper use by the user (failure to follow instructions), serial number damage, accident or natural disaster, will not be covered under the warranty.
4. The warranty will expire immediately if any alterations are made to the warranty card.
5. Please show the equipment SN and purchase certificate for repair. The company reserves the right to interpret the above contents.



UROVO TECHNOLOGY CO., LTD.

Tle: 400 888 6989

Fax: +86 755 86186290

Website: www.urovo.com

E-mail: urovo@urovo.com

Address: 36F-37F,High-Tech Zone Union Tower,No.63,Xuefu
Road,Nanshan district,Shenzhen,
Guangdong,China